

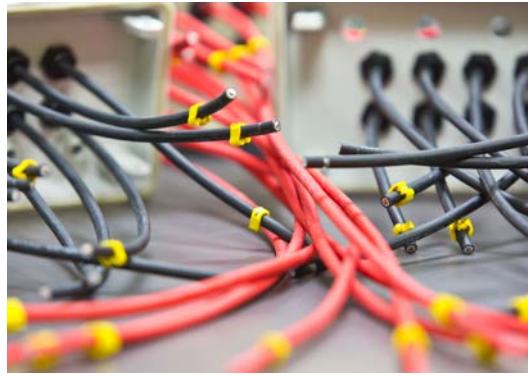

Renewable Energy:

Balance of System Solutions

MADE FOR REAL 



Interesting Facts



>460MW

Number of MW tracker control boxes supplied



>100Km

Km's of Motor cables



IATF

16949 2016



IEC61439-2

Type Tested

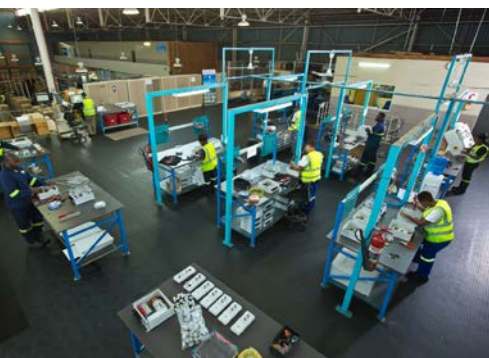

Local Manufacturing



1500V DC



Key Supplier Partnerships

NOTE: Some images and technical specifications may differ from what is included in this catalogue.

No part of this document may be reproduced or transmitted in any form or by any means, electronic or mechanical, including photocopying and recording, for any purpose, without the express written permission of HellermannTyton (Pty) Ltd.

© 2023-2024 – HellermannTyton (Pty) Ltd – All rights reserved

PV String Combiner Boxes (SCB)	6	
Custom Assemblies		
- String Combiner Boxes	7	
- Wireless Master Receiver	8	
- Fuses and Fuse Holders	9	
Cable Ties and Fixings		
- Cable Ties: T-Series UV and Weather Resistant	10	
- Cable Ties: MBT Stainless Steel	10	
- Edge Clips: 2-Piece Fixing Ties for Edges – Top Fixing	12	
- Heavy Duty Metal Clips	12	
- Series 6 Ratchet P-Clamp Solar Hanger	13	
- Cable Tie Tensioning Tools (Nylon and Stainless Steel)	14	
Patented Products		
- Rail Cradle for Cable Ties	14	
Identification Systems		
- Thermal Transfer Printer - TT431	15	
- Labels - TIPTAG PU	15	
- Thermal transfer - TAG material 1220, UV-stable identification	16	
- Solar Label Value Pack	17	
Cable Protection Systems		
- Convoluted Tubing	18	
Electrical Installations		
- PV Connectors	19	
- Dust Covers	19	
- Glands including Nylon	20-21	
- Gland Accessories	21	
- HTB Standard Lugs and Ferrules	22-23	
Wireless Technology		24
Tools – Kits		
- Solar Backpack	25	
- Electrical Tool Kit 1000V - 18 Piece	25	
Tools – Crimpers, Cutters and Strippers		
- Hand Hydraulic Crimper and Kit	26	
- PV Crimpers	26	
- Hydraulic Cable Cutter	26	
- PV Stripping Tool	26	
Instruments – Photovoltaic		
- Selection Guide Instruments	27-28	
- Solutions for Performance Optimization and Troubleshooting	28	
- Selection Guide Accessories	29	
- I-V Curve Tracer up to 1500V - DC: SOLARIV	30	
- PV Insulation Tester: PVISOTEST	31	
- Multifunction Device for Commissioning Tests: PVCHECK/PVCHECKPRO	32	
Instruments		
- Thermal and Digital Clamp Meters	33-34	
- Multimeter Clamp PV and Thermal Multimeters	35-36	

For our full product basket, please refer to our website www.HellermannTyton.co.za



Lower your OPEX costs by getting cable management right first time

HellermannTyton products connect, fasten, route, protect and identify solar cables – bringing unmatched safety, reliability and longevity to PV installations – no matter how harsh the conditions they operate under.

Whether you're looking for a more reliable cable tie, more durable identification, or an experienced designer and manufacturer to act as your advisor for best practices focusing on your total cost of energy, HellermannTyton has expertise you can call on to help keep your operational expenditure as low as possible.

MADE FOR REAL[®]

Proven performance in solar installations

Climate considerations

Selecting the right cable management solution for solar installations depends on the climate and local environmental conditions specific to the region where the plant will reside. The boundaries between climate zones are dynamic and can vary tremendously according to regional topography and specific local climatic influences.

Long-term average of global UV horizontal irradiation (GHI)

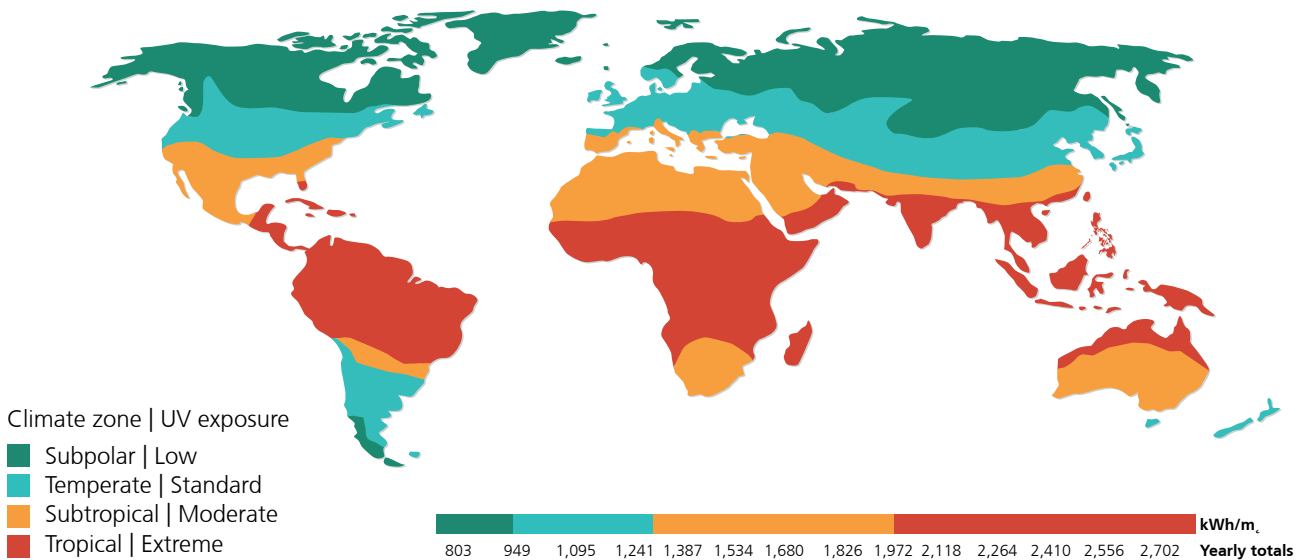

Humidity, salt in the air and altitude all affect the performance of materials. Our product engineers are ready to advise you on the best combination for your local requirements.

Part design considerations

Even the best-made clips, mounts and ties in the world will fail prematurely if they don't fit the requirements of the application. Take frame holes, they are one of the most common points where fasteners fail. The holes' sharp edges slice away at plastic parts that move with the wind and expand during the daytime heat.

Trackers and floating PV only exacerbate the problem. Poor cable management choices at the outset can lead to severe, long-term issues over the lifetime of a solar plant.

The hidden costs of poor cable management are several times greater than the cost of doing it right from the start.

Material considerations

Depending where in the world our products are deployed, we help customers make informed decisions based on environmental factors. Off-the-shelf materials are appropriate for many general-purpose applications, but not in solar. Here, the short-term savings of standard grade materials quickly transform into spiralling maintenance costs. Quality is not everything, but everything without quality is nothing.

That's why HellermannTyton offers cable management products for the solar industry from materials formulated with UV stabilizers, UV absorbers or exceptionally durable base plastics designed for long-term service and extended lifespans.

Plastic materials and their approximate performance under UV exposure.

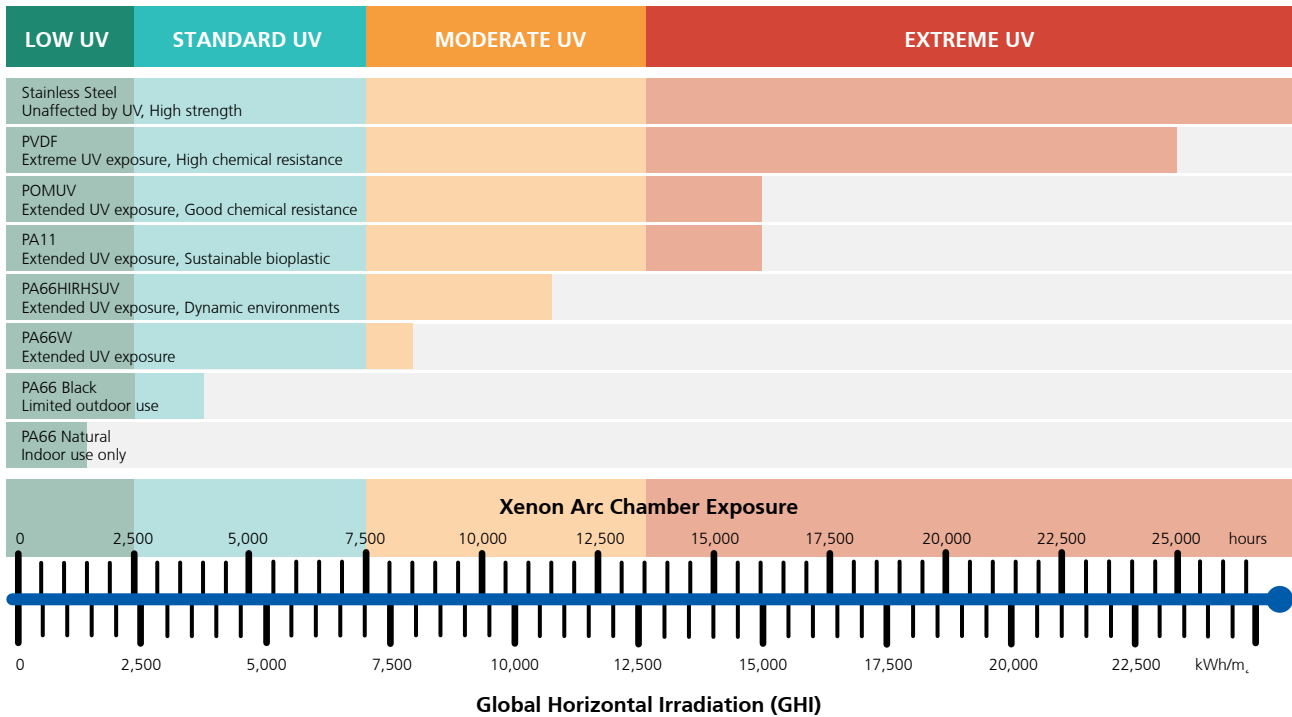

Depending on your plant design and the expected UV and chemical exposure, we offer part solutions that outperform value-priced products. Even under extreme UV exposure, our new PVDF plastic material provides the most maintenance-free cable management you can get without resorting to stainless steel.

Approximate suitability of materials to climate zones

Product base material	UV irradiation resistance	Humidity tolerance	Temperature range	Climatic zone
PA66W	☼	●	-40 °C to +85 °C, (+105 °C, 500 h)	Subpolar/Temperate
PA66HIRHSUV	☼☼	●●	-40 °C to +110 °C	Temperate
PA11	☼☼☼	●●●(-)	-40 °C to +85 °C, (+105 °C, 500 h)	Subtropical
POMUV (Polyacetal)	☼☼☼	●●●●(-)	-40 °C to +90 °C, (+105 °C, 500 h)	Subtropical
PVDF	☼☼☼☼	●●●●(-)	-55 °C to +175 °C	Tropical
Stainless steel	☼☼☼☼	●●●●(-)	-80 °C to +538 °C	Tropical

(-)Also recommended for floating PV applications.

Please note; The above information is provided for information purposes only and is not a substitute for validation tests.

UV stability of HellermannTyton cable ties

How fast or slow do plastic materials degrade under ultraviolet (UV) irradiation? To find out, HellermannTyton commissioned the Fraunhofer Institute for Solar Energy Systems (ISE) to carry out extended UV weathering tests on HellermannTyton cable ties made from plastics with different properties.

Fraunhofer ISE fastened the cable ties under load to metal cylinders and exposed them to 156.78kWh/m₂ of UV for 1600 hours at controlled intervals. This amount of artificial irradiation complies with the assumption that Central Europe is exposed to natural solar irradiation of 1,000 kWh/m² per year, with about 5% of this being in the damaging UV range. This dose corresponds to approximately three years of Central European natural solar irradiation.

To determine the functional integrity of the cable ties after each UV exposure interval, loop strength tests were performed on specimens according to section 9.5.1 of DIN EN 62275:2010-07.

Mean results of the cable tie loop strength test after artificial UV weathering

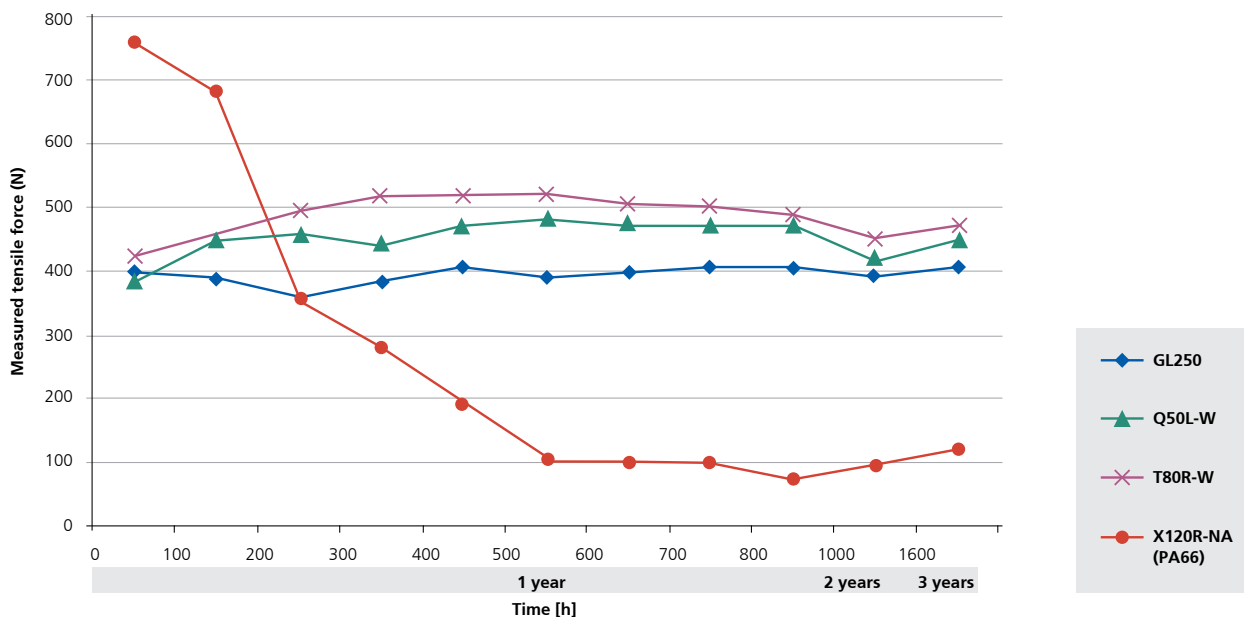

Fraunhofer ISE also collected data for T80R-W cable ties in real-time over three years at two outdoor locations, in south-western Germany and in the Negev Desert, Israel. These real-time findings affirm that the results of the accelerated UV exposure under laboratory conditions are indicative.

Natural-coloured polyamide 6.6 cable ties showed significant UV damage after only 200 hours in the test chamber. The loop tensile strength of this non-UV-stabilised material dropped to less than 50 percent of its initial value. In contrast, the T80R-W ties (UV-stabilised polyamide 6.6) and the GL250 ties (polyamide 11) showed only negligible degradation from UV exposure.

The UV-stabilised polyamide 6.6 material is reliable at this UV exposure. Importantly, 3 years of solar irradiation exposure in the Negev Desert equals approximately 6 years in Central Europe, depending on the specific local conditions. Data from the separate field test on T80R-W cable ties at a Central European location also affirmed this.

As per SANS/IEC 61439-1-2

- **712.412.2.101** Except for the inverter, equipment used on the DC side shall be **Class II**, or installed in a way to achieve equivalent insulation. Examples of such equipment are PV modules, **DC distribution boards or cabinets**.
- **712.512.1.1.102.3 - Combiner box class**
- Where the protective measure used on the DC side is double or reinforced insulation according to 712.412, **combiner boxes** shall be selected according to **Class II, double insulated material**.

The SCB enclosure for DC power

The enclosure is an intricate part of the design, and seeing that these SCB's are utilized for DC power generation, the following points need to be carefully considered when specifying these enclosures:

- **Certified and Type Tested for the application**
In the event of possible short circuits or lightning current surges, the specified enclosure should be able to withstand the heat or blast without causing any damage or injury to property or people.
- **The specified Enclosure**
International Standard - IEC61439-1-2
Protection class II and double insulated
 - The square within a square represents double insulation.
 - This warrants maximum safety with regards to an item or part of an enclosure that does not require a direct safety connection to electrical earth or ground.
 - Class II should not be confused with the designation "Class 2" as the latter has no reference to insulation, but rather the limits on maximum outputs for voltage, current or power.



PV String Combiner Boxes (SCB)

Rooftop Solar

HellermannTyton is well-known for being one of the very few suppliers who designs and manufactures String Combiner Boxes (SCB) strictly to IEC standards. One of these standards is IEC 61439-2 which refers to the enclosure used for DC SCB's and clearly states the following:

We stock the standard 2 to 5 string combiner boxes complete with isolator, type 2 surge protection, and fuse protection for both positive and negative string inputs. All these are manufactured in a certified IATF16949 certified facility.

Part of our designs are also done strictly to Kirchhoff's law for current balance and Gay Lussac's law for pressure differentials to prevent possible condensation.

Applications:

Apart from our standard stock units, we have also completed the following amongst many others:

- Customer specific designs with up to ten string inputs.
- General SCB's with shunt trip capabilities for additional safety purposes. This is also referred to as the fire-man's switch.
- We have an In-Production quality procedure ensuring the best quality of both material and workmanship throughout the production process.
- All PV pins are crimped by means of a pneumatic crimping machine. This ensures all crimps to be on the same high-quality standard.
- Every SCB has been tested by means of a fully computerized test facility.
- On delivery of an SCB, the customer will find the following inside the box:
 - » A test certificate
 - » A General Assembly (GA)
 - » A Single Line Diagram (SLD)
 - » Installation instructions
 - » If PV panel mount connectors was specified for the string inputs, a full set of PV cable connectors are supplied with the SCB to ensure the typical plug-and-play system and the same brand PV connectors being used.

HellermannTyton has successfully designed and manufactured thousands of a vast variety of rooftop SCB's strictly to international safety standards. Quality and safety are two of the subjects that will never be compromised for price.



Custom Assemblies

String Combiner Boxes



IP66
IP67

(Enclosure - Polycarbonate)

Small Installation String Combiner Boxes 1000V

- Standard design for easy installation

Technical Overview

Fuse Holders	32A/1000V DC
Fuses	15A/1000V DC
Surge Protection	Type 2/1200V DC
Isolator	63A/1000V DC
String Entry	PV connectors
Mains Exit	Compression glands



Locally designed and assembled

Type	No of Strings	Isolator	SPD	Certificates
SCB021ISOC	2	63A	Type 2	Test Certificate
SCB031ISOC	3	63A	Type 2	Test Certificate
SCB041ISO	4	63A	Type 2	Test Certificate
SCB051ISOC	5	63A	Type 2	Test Certificate

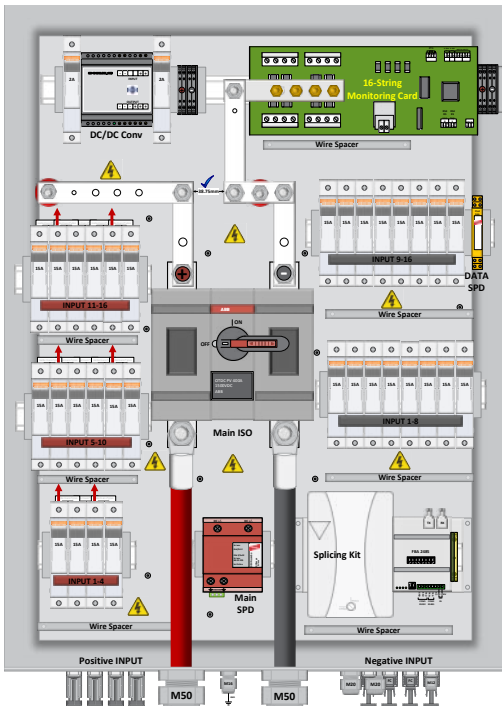

Communication
RS485 / Optical Fibre

OUT gland sizes based on
300mm² AA single cores
suitable for 27mm OD's

IP66
(Enclosure)



Locally designed and assembled

Custom Designed Combiner Boxes 1000V - 1500V

- Designed and assembled as per specification
- Type tested IEC61439-2

Technical Overview

Enclosure	GRP with hinged door – lockable options
Fuse Holder	32A/1500V DC
Fuses	20A/1500V DC
Main Surge Protection	Type 1&2/1500Vdc with auxiliary control
Isolator	400A/1500V DC with auxiliary control
Monitoring	Full string monitoring: RS485 to FO
DC/DC Converter	1500V DC/24V DC
Busbars	BS2814C102 HC Copper, Current rating up to 515A
Data Surge Protection	Type 3
String Entry	PV connectors
Mains Exit	Compression glands, vent plugs
Certificates	Type tested to: 1500V DC, SANS10142-1-2, IEC61439-2

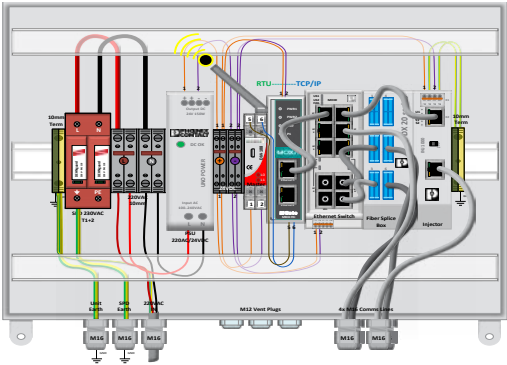

IP66
(Enclosure)

Wireless Master Receiver

- Enclosure Material: PC
- Enclosure Size: 300x400x187
- IP rating: IP66
- Class II Double Insulated
- Flame Retardant
- Self Extinguishing
- Silicon- & Halogen Free
- UV Resistant
- PSU – 220VAC/24VDC
- SPD – 230VAC, T1+2
- Enclosure standard: IEC 61439-2

Technical Overview

Enclosure	GRP with hinged door – lockable options
Fuse Holder	45A/1500V DC
Fuses	20A/1500V DC
Main Surge Protection	Type 1&2/230V AC with auxiliary control
Isolator	400A/1500V DC with auxiliary control
Monitoring	RS485 – Wireless
DC/DC Converter	1500V DC/24V DC
Busbars	BS2814C102 HC Copper, Current rating up to 515A
Data Surge Protection	Type 3
String Entry	PV Connectors, Dust Plugs
Mains Exit	Compression glands, vent plugs
Certificates	Type tested to: 1500V DC, SANS10142-1-2, IEC61439-2



Locally designed and assembled



Custom Assemblies

Fuses and Fuse Holders – 1000V/1500V



Fuse Holders 1000V and 1500V

1000V - HTPVFUSEH1000V

- DIN rail mounted (35mm)
- Single pole

Technical Overview

DC Voltage (V)	1000V
Current (A)	32A
Short-Circuit Current (SCCR)	100Ka

RoHS ✓



IP20

Model Specification

Fuse Holder Type	Cylindrical fuse links- 10x38 gPV fuse
Certificates	IEC60269-1&2, UL4248/19, CSA Certified, RoHS

1500V - HTPVFUSEH1500V

- DIN rail mounted (35mm)
- Single pole

Technical Overview

DC Voltage (V)	1500V
Current (A)	32A
Temperature (°C)	-40 to +125°C

RoHS ✓



IP20

Model Specification

Fuse Holder Type	Cylindrical fuse links- 10x38 gPV fuse
Certificates	IEC60269-2, UL4248/19, CSA Certified C22.2 No 4248.19



Fuse Links

1000V DC

Technical Overview

Type	Fuse	Voltage (V)	Current (A)
HTPVFUSE2A1000V	2A	1000	2A
HTPVFUSE15A1000V	15A	1000	15A
HTPVFUSE20A1000V	20A	1000	20A
HTPVFUSE25A1000V	25A	1000	25A
HTPVFUSE30A1000V	30A	1000	30A

Model Specification

Certificates	IEC60269-6, UL2579, RoHS, CSA Certified
Dimensions (mm)	10x38 gPV fuse

RoHS ✓

1500V DC

- Overcurrent protection

Technical Overview

Type	Fuse	Voltage (V)	Current (A)
HTPVFUSE4A1500V	4A	1500	4A
HTPVFUSE15A1500V	15A	1500	15A
HTPVFUSE20A1500V	20A	1500	20A
HTPVFUSE25A1500V	25A	1500	25A
HTPVFUSE30A1500V	30A	1500	30A

Model Specification

Certificates	IEC60269-6, UL2579, RoHS, CSA Pending
Dimensions (mm)	10/14 x 85 gPV fuse

IP20



Cable Ties - UV and Weather Resistant

T-Series, PA66W (black)

- Operating temperature -40°C to +85°C
- Flammability UL94 V2
- High tensile strength with very low insertion force
- Inside serrated cable ties for a strong hold onto bundles
- Easily installed either by hand or with a tensioning tool

HF ✓ RoHS ✓



Locally Manufactured

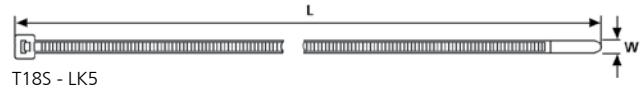

Type	Width (W)	Length (L)	Bundle Ø max.	N	Material	Colour	Qty	Article-No.
T18RWBK	2.5	100	22	80	PA66W	Black (BK) ■	100	111-02187
T30RWBK	3.5	150	35	135	PA66W	Black (BK) ■	100	111-02188
T50RWBK	4.6	200	35	135	PA66W	Black (BK) ■	100	111-02191
T50IWBK	4.6	305	85	225	PA66W	Black (BK) ■	100	111-02194
T50LWBK	4.6	390	110	225	PA66W	Black (BK) ■	100	111-02195
T120RWBK	7.6	390	105	535	PA66W	Black (BK) ■	50	111-02193
LK5WBK	13.2	535	150	1 115	PA66W	Black (BK) ■	50	111-02192

Recommended Tools

Type	MK10TEN	EV07i
Page	9	9



Cable Ties with Ball-Lock

MBT-Series (SS316)

- Non-releasable locking feature
- Operating temperature -80°C to +538°C
- Corrosion and weather resistant
- Outstanding chemical resistance
- Anti-magnetic
- Non-burning

HF ✓ RoHS ✓ LFH ✓

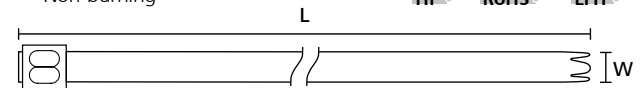

Type	Width (W)	Length (L)	Bundle Ø max.	N	Material	Article-No.
MBT5S	4.6	127	25	670	SS316	911-01947
MBT8S	4.6	201	50	670	SS316	911-01948
MBT14S	4.6	362	102	670	SS316	911-01950
MBT20S	4.6	521	152	670	SS316	911-01952
MBT8H	7.9	201	50.8	1115	SS316	911-01949
MBT14H	7.9	362	102	1115	SS316	911-01951
MBT20H	7.9	521	152	1115	SS316	911-01953
MBT27H	7.9	681	203	1115	SS316	911-01954

Recommended Tools

Type	HT338	MK9SST
Page	9	9

Comprehensive part solutions for reliable solar cabling

MADE FOR REAL 

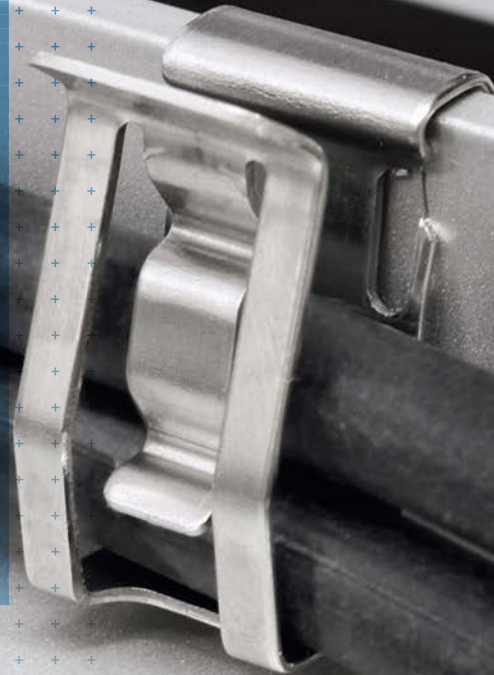



2-Piece Fixing Ties for Edges, 1-3mm, Top Fixing

EdgeClip (Black)

- Pre-assembled 2-Piece fixing tie with EdgeClip
- Cable tie head can be moved after bundling
- For edges of 1-3mm
- Harsh environments
- Available in black only

RoHS ✓

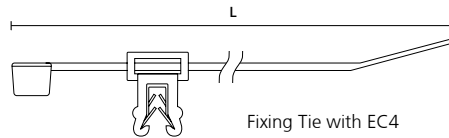

Type	Drawing	Width (W)	Length (L)	Bundle Ø max.	N	Material Cable Tie	Material Foot Part	Article-No.
T50ROSEC4A-W		4.6	200	45	225	PA66W	PA66W	156-00570

All dimensions in mm. Subject to technical changes.

Recommended Tools

Type	MK10TEN	EV07i
Page	9	9



Heavy Duty Metal Edge Clips

MSC2

- Integrated design allows for easy insertion by hand
- Panel thickness range allows for multiple applications
- Double-compression design accommodates various wire and cable sizes
- High extraction force withstands extreme conditions
- Operating temperature -80°C to +538°C

RoHS ✓

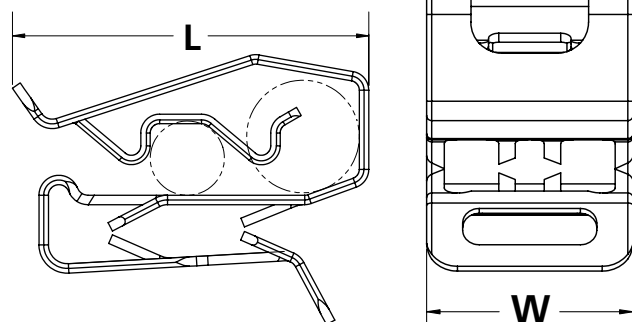

Type	No of Cables	Max Cable (mm)	Min Cable (mm)	Panel Thickness (mm)	Length (L) (mm)	Width (W) (mm)	Material
HTPV2CC	2	7.6	5	1-3	24	13	SS304
PV2CC90	2	7.6	5	1-3	18.6	11.3	SS304
PV2CC6MM	2	6.0	5	1-3	20.3	10	SS304
PV4CC6MM	4	6.0	5	1-3	33.7	10	SS304

All dimensions in mm. Subject to technical changes.



Cable Ties and Fixings

Ratchet P-Clamps



Series 6 Ratchet P-Clamp Solar Hanger

Size B: Series 6 RPC Hanger for Bundle Diameters 12.7 - 19.5mm (Black)

- Temperature -40°C to +105°C
- Impact modified, heat and UV stabilized PA66 provides long-term durability in solar applications
- One-piece ratchet closure design allows for easy installation by hand during pre- or final assembly on First Solar Modules
- Integrated release feature allows for quick adjustments and maintenance
- First Solar specific steel mounting hanger tolerates high torque and is chemical resistant
- Non-destructive easy release with a flat-head screwdriver, allows clamp to be reused, adjusted without removing it
- Adjustable clamp can be closed by hand to desired diameter, replacing multiple sizes of fixed diameter fasteners
- Flammability UL 94 HB
- Material: Polyamide 6.6 high impact modified, heat and UV stabilized (PA66HIRHSUV), Zinc plated (ZN)

RoHS ✓

Type	Min. Bundle Diameter (mm)	Max. Bundle Diameter (mm)	Length (L2) (mm)	Width (W) (mm)	N	Mounting Hole Ø (FH) (mm)	Qty	Article-No.
RCBHANGER	12.7	19.5	81.7	34.9	445.0	5.6	280	151-02875

Dimensions are approximate and subject to technical changes.



Series 6 Ratchet P-Clamp Solar Hanger

Size C: Series 6 RPC Hanger for Bundle Diameters 19.4 - 36.0mm (Black)

- Temperature -40°C to +105°C
- Impact modified, heat and UV stabilized PA66 provides long-term durability in solar applications
- One-piece ratchet closure design allows for easy installation by hand during pre- or final assembly on First Solar Modules
- Integrated release feature allows for quick adjustments and maintenance
- First Solar specific steel mounting hanger tolerates high torque and is chemical resistant
- Non-destructive easy release with a flat-head screwdriver, allows clamp to be reused, adjusted without removing it
- Adjustable clamp can be closed by hand to desired diameter, replacing multiple sizes of fixed diameter fasteners
- Flammability UL 94 HB
- Material: Polyamide 6.6 high impact modified, heat and UV stabilized (PA66HIRHSUV), Zinc plated (ZN)

RoHS ✓

Type	Min. Bundle Diameter (mm)	Max. Bundle Diameter (mm)	Length (L2) (mm)	Width (W) (mm)	N	Mounting Hole Ø (FH) (mm)	Qty	Article-No.
RCCHANGER	19.4	36.0	101.7	34.9	445.0	5.6	160	151-03057

Dimensions are approximate and subject to technical changes.

Cable Ties and Fixings

Cable Tie Tensioning Tools and Patented Product

Nylon Cable Ties (Steel Frame)

MK10TEN

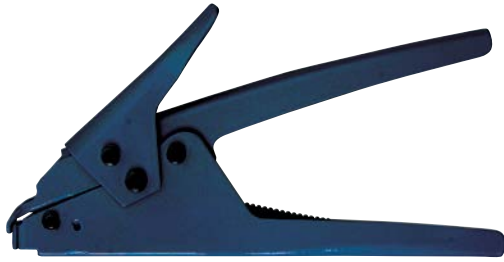

- Adjusting tensioning force
- Lightweight tool ideal for continuous use in high volume production
- **T18, T50 and T120** series cable ties
- Maximum width of tie: 9.5mm
- Dimensions (mm): 190(L) x 95(H) x 30(W)
- Weight: 500g



Nylon cable tie tensioned and cut i.e. no sharp edges

Nylon Cable Ties (Plastic Frame)

EVO7i



- Adjustable preset tension tool
- Tensions and automatically cuts cable ties up to 4.8mm wide
- Extremely low maintenance
- Housing made of resilient and lightweight glass fibre-reinforced polyester MIL approved
- Dimensions: (mm): 191(L) x 33(W)
- Weight (g): 781



Nylon cable tie tensioned and cut i.e. no sharp edges

Stainless Steel Cable Ties (Plastic Frame)

HT338



- Fastens and automatically cut ties with adjustable bundling pressure
- Tension adjusting indicator
- Cable tie thickness up to 0.3mm. Width up to 7.9mm
- **MBT8, MBT14, MBT20 and MBT27** cable ties



Stainless steel cable tie tensioned and cut i.e. no sharp edges

Stainless Steel Cable Ties (Plastic Frame)

MK9SST



- Lightweight tool ideal for continuous use in high volume production
- MBT series cable ties
- Maximum width: 4.6 - 16mm
- Dimensions (mm): 190(L) x 150(H) x 40(W)
- Weight: 600g
- Spare blades: **HT338BLD, HT385RAT, SPMK9SST**



Stainless steel cable tie tensioned and cut i.e. no sharp edges



3-D



Rail Cradle for Cable Ties

T50RUNICLIP

- Clip around solid side to each lip of unistrut
- Built in cable tie mount
- Cable tie can be inserted multi directional
- Cable to run along unistrut
- Based on TY self-adhesive cable tie mount design
- Cable ties sold separately

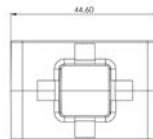

Technical Overview

Material	PA66W
Properties	Weather stable
Dimensions (mm)	42(L) x 42(W) (inside clip/outside of rail)
Unistrut	P1000 and P2000
Cable tie	T50



Patented and locally manufactured

Cable Ties and Fixings

Printer and Labels



Thermal Transfer Printer

TT431, Small to Medium Print Volumes

- Standard applications e.g. barcodes (2D), warning symbols, graphics and alphanumeric characters
- Thermal Transfer material:
 - TIPTAG cable markets
 - Shrinkable markers
 - Labels
- Colour touch display with clear menu tree structure
- Windows compatible
- TTRC ink ribbon recommended

Technical Overview

Article-No. (Order Code)	556-00400
Print Method	Thermal transfer
Print Resolution (dpi)	300
Max Print Speed (mm/s)	150
Max Print Width (mm)	105.7
Interface	3x USB ports – all support 500mA
Storage	RAM up to 256MB Flash 50MB
Software	TagPrint Pro 4.0 (sold separately)
Dimensions (mm)	243(W) x 189(H) x 322(L)
Weight (kg)	4



Colour touch screen with menu based on smartphone functionality



Identification Tags for Cable Bundle, Thermal Transfer

TIPTAG PU – UV-stabilised

- Operating temperature -65°C to +120°C, intermittent temperature +150°C
- Flammability self-extinguishing, UL 94 V0 (3mm)
- Suitable for retrofit purposes
- Durable and robust polyurethane material
- For large cable bundles and wires
- Harsh environments
- Weather and abrasion resistant
- Good resistance to chemicals
- Perforated format with fastening slots for cable ties
- TTRC ink ribbon recommended

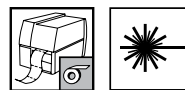

RoHS ✓



Durable ribbon developed to create a "tattoo" effect to prevent marking from being rubbed off

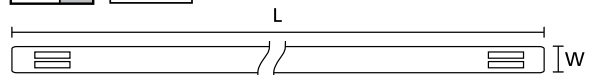

Type	Length (L)	Width (W)	Material	Colour	Qty	Article-No.
TTAGPU11X65WH	65	11	PUR DS	White (WT) <input type="checkbox"/>	190	556-25012
TTAGPU11X65YE	65	11	PUR DS	Yellow (YL) <input checked="" type="checkbox"/>	190	556-25019
TTAGPU15X65WH	65	15	PUR DS	White (WT) <input type="checkbox"/>	190	556-25007
TTAGPU15X65YE	65	15	PUR DS	Yellow (YL) <input checked="" type="checkbox"/>	190	556-25011
TTAGPU11X100WH	100	11	PUR DS	White (WT) <input type="checkbox"/>	125	556-25021
TTAGPU11X100YE	100	11	PUR DS	Yellow (YL) <input checked="" type="checkbox"/>	125	556-25020
TTAGPU15X100WH	100	15	PUR DS	White (WT) <input type="checkbox"/>	125	556-25006
TTAGPU15X100YE	100	15	PUR DS	Yellow (YL) <input checked="" type="checkbox"/>	125	556-25010

All dimensions in mm. Subject to technical changes.

Minimum Order Quantity (MOQ) may differ from package content. Other packaging options may also be available. More colours on request.

Identification labels, thermal transfer

TAG material 1220, UV-stable identification

Panel labels are durable adhesive labels especially made from a thick material that is designed to replace traditional engraved plastic plates. Ideal for panel row marking and string inverter rack identification. Create crisp and clear professional-looking labels by printing with HellermannTyton thermal transfer printers and ribbons. Simple label design creation is easily achieved using separately available TagPrint Pro software.

- Cost-effective replacement for engraved plastic plates
- No need for additional label holder
- High-performance adhesive and compressible foam backing
- Optimal adhesion ensured on uneven surfaces
- Rounded corners ensure better long term durability of adhesion
- High contrast text and barcodes
- Tested for a minimum of 10 year's UV performance
- Print on site instead of order off site
- Outstanding chemical resistance with TT122OUT ribbon

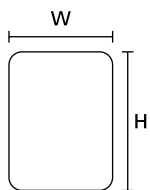

Material	Type 1220, Polyester, white (1220)
Operating Temperature	-40 °C to +90 °C
Curing Temperature	from +10 °C
Adhesive	Acrylic
Thickness of Foil	50 µm
Chem. Material Properties	Excellent resistance to aging, weathering and UV-radiation. Extensive resistance to the influence of chemicals and solvents.
Recommended Ribbon Type	TT122OUT, TT822OUT
Thermal Transfer Printer	TT431, TT4030

RoHS ✓

Type	Width (W)	Height (H)	Width of Liner (WL)	Labels per Row	Pack Cont.	Colour	Article-No.
TAG60-30TDK1-1220-WH	60	30	66	1 pc.	500 pcs.	White (WH)	596-00569
TAG90-45TDK1-1220-WH	90	45	96	1 pc.	500 pcs.	White (WH)	596-00570
TAG100-30TDK1-1220-WH	100	30	106	1 pc.	250 pcs.	White (WH)	596-00571
TAG100-70TDK1-1220-WH	100	70	106	1 pc.	250 pcs.	White (WH)	596-00572

All dimensions in mm. Subject to technical changes.

Minimum Order Quantity (MOQ) may differ from package content. Other packaging options may also be available.

Identification Systems

PV Solar Labels

Solar Label Value Pack

Solar Label Value Pack Part No.: SOLAR946 (596-03945)

- Assortment of the labels required for NEC 2020 code compliance
- All labels made from UV stable vinyl and dye-based inks and protected by weather-resistant laminate
- Long-lasting, permanent adhesive ensures high-performance results on a variety of metals, paints and man-made materials

Size: 6" x 4" • Qty: 1

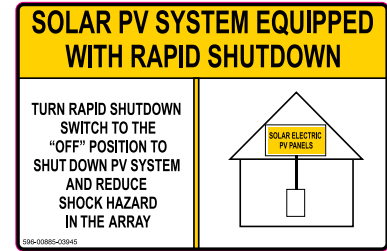

Size: 5.5" x 1.75" • Qty: 1



Size: 5" x 1" • Qty: 1



Size: 6.5" x 1" • Qty: 6



Size: 6.5" x 1" • Qty: 1



Size: 6.5" x 1" • Qty: 6



Size: 6.5" x 1" • Qty: 1



Size: 4" x 1" • Qty: 1



Size: 4" x 1" • Qty: 1



Size: 4" x 1" • Qty: 2



Size: 4" x 1" • Qty: 1



Size: 3.75" x 1" • Qty: 2



Size: 3.75" x 1" • Qty: 2



Size: 3.75" x 1" • Qty: 1



Size: 3.75" x 1" • Qty: 1



Size: 4" x 2" • Qty: 1



Size: 4" x 2" • Qty: 1

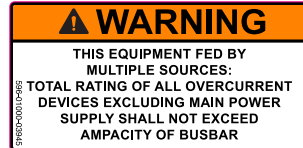

Size: 4" x 2" • Qty: 1



Size: 4" x 2" • Qty: 1

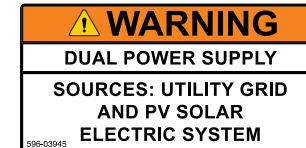

Size: 3.75" x 2" • Qty: 1

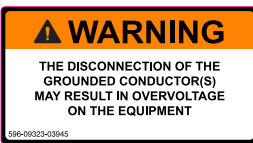

Size: 3.75" x 2" • Qty: 2

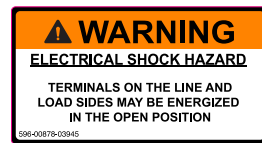

Size: 3.75" x 2.5" • Qty: 1

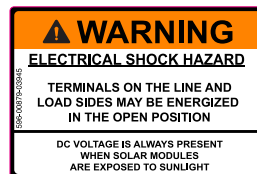

Size: 2" x 1.25" • Qty: 1



Size: 4.125" x 0.75" • Qty: 2



Size: 4.125" x 0.75" • Qty: 1



Size: 4" x 1" • Qty: 1



Size: 4" x 1" • Qty: 1



Size: 4" x 1" • Qty: 1



Size: 6.5" x 1" • Qty: 1



Size: 3.75" x 5" • Qty: 1

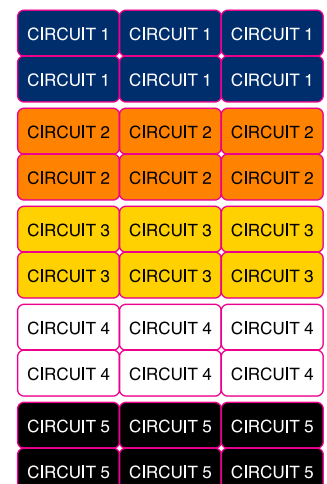



Convuluted Tubing

Medium Duty (High Impact), PVC (Grey)

- Operating temperature -5°C to 60°C
- Compression force 740N
- High impact, flexible, UV stable
- Durable, crush resistant
- Meets requirements of SABS IEC 60614-1:1994 and IEC 60614-2-3:1990 – Pliable conduits for electrical installations
- Authorisations Committee approval number 0211064

RoHS ✓

Type	Nominal Size (mm)		Material	Colour	Length (m)	Article-No.
	IØ	OØ				
V20HT3905	15.5	20	PVC	Grey (GY) ■	50	911-01831
V25HT3905	20.5	25	PVC	Grey (GY) ■	50	911-01841

All dimensions in mm. Subject to technical changes.



Convuluted Tubing

Medium Impact, PVC (Black)

- UV Stabilized 3- 5 years
- Manufactured from Nylon PA66
- Operating temperature -40°C to 150°C
- Flame retardant and heat resistant
- Flexible

RoHS ✓

Type	Nominal Size		Material (p4)	Colour	Length (m)	Article-No.
	IØ	OØ				
CTPA17NWUV	17	21	Nylon PA66 + 5% UV Stabilizer	Black (BK) ■	100	911-21405
CTPA22NWUV	22	26	Nylon PA66 + 5% UV Stabilizer	Black (BK) ■	100	911-21406
CTPA28NWUV	28	32	Nylon PA66 + 5% UV Stabilizer	Black (BK) ■	100	911-21407

All dimensions in mm. Subject to technical changes.



Electrical Installations

PV Connectors and Dust Covers



IP68

PV Connectors

- Connects modules into series string
- From DC home-run to inverter
- DC Voltage (V): Up to 1000V
- Current (A): 20A - 30A
- Temperature: -40°C to +85°C
- Protection Class: II

PV Connector

Type	Description	Dimensions	Connector Material	Contact Material
PVC46F	Female	4 - 6	PPO	Silver plated copper
PVC46M	Male	4 - 6	PPO	Silver plated copper



PV Branch Connector

Type	Description	Dimensions	Connector Material	Contact Material
PVBC2F1M	2F-1M	4 - 6	PPO	Silver plated copper
PVBC1F2M	2M-1F	4 - 6	PPO	Silver plated copper



PV Connector Pin

Type	Description	Dimensions	Connector Material	Contact Material
PVP46F	Female	4 - 6	PPO	Silver plated copper
PVP46M	Male	4 - 6	PPO	Silver plated copper

All dimensions in mm. Subject to technical changes.



Dust Covers

- Prevents possible damage of male or female pin due to:
 - Dust and water ingress
 - Connections causing hot connection
- Compatible with most PV Connectors
- Suitable for:
 - PV panel mount connectors
 - PV cable connectors
 - PV branch connectors



Locally manufactured

Product Overview

Type	Description	Colour
DCOVERF100	Female Dust Cover	Black (BK) ■
DCOVERM100	Male Dust Cover	Black (BK) ■



Rotary Cone Glands

BWR Range

- All types of SWA cable
- Clamping of armour wire for earth continuity and mechanical retention of cable
- Used indoor and outdoor
- Easy to install (rotary cone)
- Protects armour wire
- Nickel plated brass glands
- SABS 1213 approved, permits available on request

Accessories

- PVC or rubber shrouds (p17)
- Earth tags (p17)

Type	Size	Entry	Bedding Ø max.	Cable Ø max.	Article-No.
BWR0	No 0	20	12.5	14.8	911-01117
BWR1	No 1	20	15.7	18.7	911-01118
BWR2	No 2	25	20.6	24.4	911-01119
BWR3	No 3	32	26.5	30.0	911-01120
BWR4	No 4	40	35.0	39.5	911-01121
BWR5	No 5	50	44.0	49.0	911-01122
BWR6	No 6	63	56.0	62.2	911-01123
BWR7	No 7	75	68.0	74.0	911-01124

All dimensions in mm. Subject to technical changes.



Loose Cone Glands

BWL Range

- All types of SWA cable
- Clamping of armour wire for earth continuity and mechanical retention of cable
- Used indoor and outdoor
- Easy to install (rotary cone)
- Protects armour wire
- Nickel plated brass glands
- SABS 1213 approved, permits available on request

Accessories

- PVC or rubber shrouds (p17)
- Earth tags (p17)

Type	Size	Entry	Bedding Ø max.	Cable Ø max.	Article-No.
BWL0	No 0	20	12.5	14.08	911-01125
BWL1	No 1	20	15.7	18.7	911-01126
BWL2	No 2	25	20.6	24.4	911-01127
BWL3	No 3	32	26.5	30.0	911-01128
BWL4	No 4	40	35.0	39.5	911-01129
BWL5	No 5	50	44.0	49.0	911-01130
BWL6	No 6	63	56.0	62.2	911-01131
BWL7	No 7	75	68.0	74.0	911-01132

All dimensions in mm. Subject to technical changes.

Electrical Installations

Glands



Compression Glands

A2 Range

- Nickel-plated brass glands
- All types of 'unarmoured' cable
- Used indoor and outdoor
- Easy to install
- Displacement seal concept ensures effective seal to the outer sheath
- Novel seal design accommodates wide cable range
- SABS 1213 approved, permits available on request

Type	Size	Entry	Bedding Ø (max.)	Cable Ø (max.)	Article-No.
A200	No 00	20	3	8	911-01142
A20	No 0	20	9	12	911-01143
A21	No 1	20	12	15	911-01144
A22	No 2	25	15	19	911-01145
A23	No 3	32	21	27	911-01146
A24	No 4	40	27	36	911-01147
A25	No 5	50	37	45	911-01148
A26	No 6	63	45	57	911-01149
A27	No 7	75	57	69	911-01150

All dimensions in mm. Subject to technical changes.



Glands

Metric, PVC, Nylon (Black and White)

- Multipurpose application
- Watertight
- Easy to assemble
- Good strain relief
- Wide clamp range
- Multiple interlock facets guarantee equal compression against cable
- Metric thread: 20 x 1.5mm

Type	Size	Clamping Range Ø	Thread Length	Material	Colour
BCS1WT*	No 1	10 to 12.5	13	ABS	White (WT) <input type="checkbox"/>
BS0BK	No 0	8.5 to 10.5	13	ABS	Black (BK) <input checked="" type="checkbox"/>
BS0WT	No 0	10 to 12.5	13	ABS	White (WT) <input type="checkbox"/>
BS1BK	No 1	8.5 to 10.5	13	ABS	Black (BK) <input checked="" type="checkbox"/>
BS1WT	No 1	10 to 12.5	13	ABS	White (WT) <input type="checkbox"/>

All dimensions in mm. Subject to technical changes.

*Nylon glass-filled

Gland Accessories

Type	Shroud PV & Rubber	Brass Earthing Tag



All glands should only be installed by qualified electricians

HTB Standard Lugs and Ferrules

Approvals:

- Mark scheme permit available on request

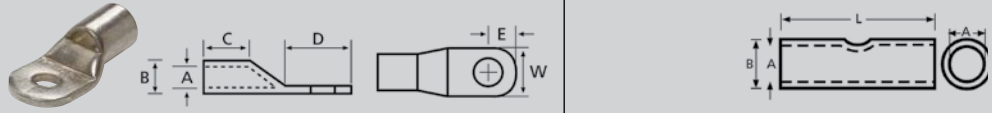
Cable Size (mm ²)	Lug				Ferrule			
								
	Type	Stud	Barrel: A (IØ)	Spade: W	Type	A (IØ)	B (DØ)	L
1.5	HTB13 HTB14 HTB15 HTB16	3-6	1.8	8	HTB1F	1.8	3.7	12
2.5	HTB23 HTB24 HTB25 HTB26 HTB28	3-8	2.4	8-12	HTB2F	2.4	4	15
4	HTB43 HTB44 HTB45 HTB46 HTB48 HTB410	3-10	3.1	10-14	HTB4F	3.1	4.8	15
6	HTB64 HTB65 HTB66 HTB68 HTB610	4-10	3.4	10-15	HTB6F	3.4	5.1	15
10	HTB105 HTB106 HTB108 HTB1010 HTB1012	5-12	4.5	12-19	HTB10F	4.5	6.2	22
16	HTB165 HTB166 HTB168 HTB1610 HTB1612 HTB1616	6-16	6.5	12-24	HTB16F	5.5	7.2	22
25	HTB256 HTB258 HTB2510 HTB2512 HTB2516	6-16	6.9	13-24	HTB25F	6.9	8.9	24
35	HTB356 HTB358 HTB3510 HTB3512 HTB3516	6-16	8.2	15-24	HTB35F	8.2	10.6	27
50	HTB506 HTB508 HTB5010 HTB5012 HTB5016 HTB5020	6-20	10	18-26	HTB50F	10	12.9	30
70	HTB706 HTB708 HTB7010 HTB7012 HTB7016 HTB7020	6-20	11.7	21-30	HTB70F	11.7	15.2	34

Crimping Terminals

HTB Standard Lugs and Ferrules

Cable Size (mm ²)	Lug				Ferrule			
	Type	Stud	Barrel: A (IØ)	Spade: W	Type	A (IØ)	B (DØ)	L
95	HTB958 HTB9510 HTB9512 HTB9516 HTB9520	8-20	13.5	25-30	HTB95F	13.5	17.4	38
120	HTB1208 HTB12010 HTB12012 HTB12016 HTB12020	8-20	15.5	28-32	HTB120F	15.5	19.8	42
150	HTB1508 HTB15010 HTB15012 HTB15016 HTB15020	8-20	17	30-32	HTB150F	17	21.7	48
185	HTB18510 HTB18512 HTB18516 HTB18520	10-20	18.5	34-36	HTB185F	18.5	23.5	53
240	HTB24010 HTB24012 HTB24016 HTB24020	10-20	21.5	38-40	HTB240F	21.5	27	60
300	HTB30010 HTB30012 HTB30016 HTB30020	10-20	24.5	43-45	HTB300F	24.5	31	67
400	HTB400		28.5	50	HTB400F	28.5	36.5	80
500	HTB500		31.5	56	HTB500F	31.5	40.5	90
630	HTB630		35	65	HTB600F	35	49	110



We did it again!

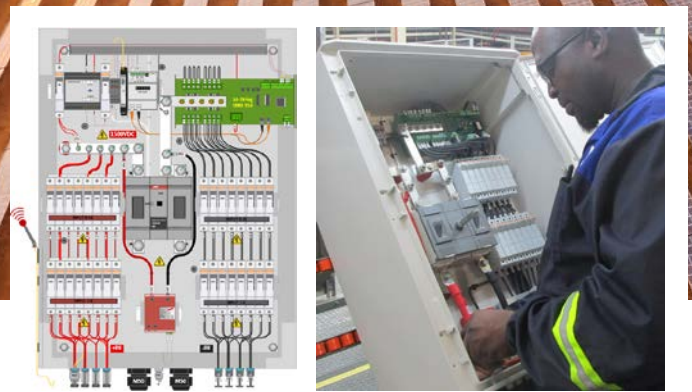

HellermannTyton are not the first to apply wireless technology, but within the renewable energy spectrum, we are among the first to successfully design and produce wireless communication into a large commercial PV solar farm in South Africa.

Growing uncertainty and unreliability of the national grid has forced both individuals and large entities to generate their own electricity. One particular mining group has joined forces with another to generate their own electricity. Despite initial concerns of viability and costs, the project covers a massive fifth of the mine's power and will save them 120 Million Rand a year in electricity bills.

The forty Megawatt (40MW) solar farm is the first in a series of plants planned for the mining group. It will offer the mine the confidence to do positive planning. This will result in increased production which can eventually lead to South Africa finding relief from the current strain of the energy crisis. Renewable energy is not a quick solution but is certainly a step in the right direction to ensuring cleaner and sustainable energy practices.

To better illustrate what 40MW generation of energy means, we can observe the following:

- A medium size dwelling consumes approximately 4500 Watts.
- 40MW is equivalent to 40 000 000 Watts.
- This means that the 40MW plant can continuously run almost 9000 mid-size houses or 14 000 smaller houses.

The endeavour marks the first of many for the mining group with further renewable energy projects currently up and running.

More importantly, let's look at HellermannTyton's contribution in directing this mining group towards renewable energy practices:

- We designed and produced 342 String Combiner Boxes (SCB's).
- The purpose of these SCB's is to safely gather the energy produced by the 116 000 solar panels or modules. The panels cover the same area as two hundred soccer field would.
- The 40MW power is combined and limited to a maximum of 1500V DC by our SCB's. This DC power is an extremely dangerous energy or voltage (the average home is supplied with 230V AC power and is considered "safe for general use").
- To combine 1500V DC in one SCB, we must adhere to very stringent safety factors and subject ourselves to the full responsibility and accountability for the safety of both people and the environment.
- For the owners and investors of the plant to see that the designed 40MW system is generating the intended energy, our SCB's must send a total of 13680 communication signals every second. This is a total of 1 181 952 000 (1.18 billion) signals every 24 hours.
- All these signals are sent wirelessly from our SCB's. These are then converted to visual images and characters on the SCADA system in the control room.

Try to imagine that only one signal out of the 1.18 billion signals in a 24hr period does not find its target or offers false information.



* LIFETIME WARRANTY



Solar Tool Backpack

PVBP

- Suitable for harsh and demanding environments
- Conforms to safety standards
- Backpack water resistant
- Quality tools with lifetime warranty
- Weight: 8kg (Max weight capacity 12kg)
- 1000V insulated tools included

Code	Description
AW100	Wrench Adjustable 100mm
CC22	Cable Cutter 25mm ²
H015	Junior Hacksaw, (Blade length 150mm)
HAMPB300	Ball Pein Hammer 300g
HT100205	1000V Insulated Combination Plier 205mm
HT104200	1000V Insulated Long Nose Plier 200mm
HT112180	1000V Insulated Diagonal Cutter 180mm
HT20013	1000V Insulated Open-Ended Spanner 13mm
HT21014	1000V Insulated Ring Spanner 14mm
INSSET	8 Piece 1000V Insulated Screwdriver Set with Neon Voltage Tester 
O1604LM	7 Piece Allen Key Set 2.5-10mm
PVCT46	Crimper 2.5 - 6mm, solar cable
PVST46	Solar Cable Stripper 2.5 - 6mm ²
HYAC5	Crimp Tool Bootlace 0.5 - 6mm ²
HD16L	Crimper 1.5 - 16mm ²
HUK1	Universal Panel Key
SW10	Socket Driver 10mm
TOOLBAGBP	Bag dimensions (mm): 460(L) x 380(W) x 210(D)

Electrical Tool Kit 1000V



PK1000V

- 18 Piece
- Quality tools with lifetime warranty
- High voltage



* Tools only

* LIFETIME WARRANTY

Code	Description
45092	Stripmaster 0.75-6mm ²
AW200	Adjustable Spanner 200mm
CC38	Cable Cutter 38mm ²
HCP200H	1000V Plier 200mm
HDC205H	1000V Diagonal Cutter 200mm
HLN200	1000V Long Nose Plier 200mm
HUK1	Universal Panel Key
INSSET	8 Piece 1000V Insulated Screwdriver Set with Neon Voltage Tester 
LEDTORCH	LED Weatherproof Torch
T235H	TRMS Digital Multimeter – 1999 Counts 
WAK2	Manual Retractable Utility Knife (Blade length 60mm)
PCS	Bag dimensions (mm): 390(L) x 240(W)

Hand Hydraulic Crimper

HYCP400

- Excludes dies

Hand Hydraulic Crimper Kit

HYCP400KT

- Excludes dies

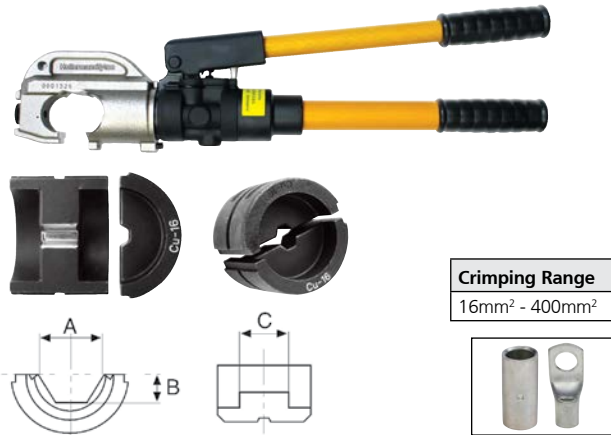

Crimping Range
16mm ² - 400mm ²

- Automatic low/high - pressure conversion with rapid/slow operating motion
- Pressure relief valve for overload protection
- Head rotates 180°
- Force at die face: 12 metric ton (700 bar)
- C-head opening: 32mm
- Dies sold separately
- Dimensions (mm) 377(L) x 142(W)
- Weight: 6.5kg

Die Code	DIE No.	A	B	C
CP40016D	Cu-16	7.2	3.12	14
CP40025D	Cu-25	8.43	3.67	14
CP40035D	Cu-35	10	4.33	16
CP40050D	Cu-50	11.6	5.02	16
CP40070D	Cu-70	13.7	5.95	15.6
CP40095D	Cu-95	15.9	6.85	15.7
CP400120D	Cu-120	17.98	7.79	16
CP400150D	Cu-150	20.1	8.7	15
CP400185D	Cu-185	22.33	9.67	14
CP400240D	Cu-240	25.43	11.01	13
CP400300D	Cu-300	28.44	12.32	11.2
CP400400D	Cu-400	30	14.55	11.5

Hydraulic Cable Cutter

HYCC85



- Two stage pumping action for rapid blade advance
- Lock pin type cutting head
- Head rotates 180°
- Output: 4.9 tons
- Cuts: Copper strands - 28mm
Aluminium strands - 38mm
Telephone cable CCP - 85mm
Underground cable - 50mm[#]
- Dimensions (mm): 715 (L)
- Weight: 10kg



Copper Cable

PV Stripping Tool

PVST46



- Insulation stripping distance guide
- Automatic spring release action
- Non-slip grip
- Standard die for 2.5, 4, 6mm² (AWG14, 12, 10) solar PVC cable

Parameter	Metric	AWG
Die range	2.5, 4, 6	14, 12, 10

* All heads require a hydraulic pump
Except armoured cable

Crimper: PV (Solar)

PVCT46



- Adjustable crimping pressure
- MC4 Solar connectors / Solar PV cable
- Right angle head design - Prevents wrist bending
- Pull force on crimping pins - 45kg

Crimping Range	
Metric	AWG
2.5mm ²	10mm ²
4mm ²	12mm ²
6mm ²	14mm ²



Accessories

Code	Description
PVCT46DIE	Replacement Die

Crimper: PV (Solar)

PVCT46B



- Standard die for 2.5/4/6mm² (AWG14/12/10) solar PV cable
- Designed for Bizlink connectors

Crimping Range	
Metric	AWG
2.5mm ²	10mm ²
4mm ²	12mm ²
6mm ²	14mm ²



Instruments

Photovoltaic Instrument - Selection Guide



MAINTENANCE AND EFFICIENCY OF THE PHOTOVOLTAIC SYSTEM	SOLARIV	PVISOTEST	PVCHECK
PAGE NO.	30	31	32
Continuity of protective conductors with 200mA		•	•
Insulation measurement with test voltage 250, 500, 1000V DC with no service interruption		x +1500V DC	•
I-V Curve measurement on single module or string	•		
VOC and ISC measurement on single module or string	•		•
Single- and 3-Phase efficiency measurement	1MPPT		
DC side efficiency of the photovoltaic field			•
Use of remote unit SOLAR02 with USB \ RF connection	RF		RF
Measurement of irradiation with reference cell	•		•
Temperature of cell and environment	•		•
POWER QUALITY ANALYSIS			
AC/DC voltage in single-/3-phase systems		•	DC
AC/DC current in single-/3-phase systems		•	DC
Cosphi, Power Factor			
Voltage unbalance (NEG%, ZERO%)			
Power/Energy: Active P, Reactive Q, Apparent S	Only active P		Only active P
Voltage and current harmonics up to the 49 th with THD%			
Voltage anomalies (dips, peaks) with 10ms resolution (at 50Hz)			
Voltage fast transients (spikes) with 5µs resolution (200kHz)			
Electric motor starting current (INRUSH)			
Voltage flickers (Pst, Plt)			
Phase sequence			
Neutral-Ground Voltage			
Neutral current			
MEMORY AND RECORDING			
Internal memory capacity	249 curves I-V 8 days@ PI =10min	999	999 Locations
Recording with selectable integration period	5s-60min		5s-60min
Indicative memory duration(in days at PI=10min at max number of parameters)	8		
Indication of recording duration for power quality analysis			•
Internal memory extension with compact flash card			•
Default and custom recordings			
REAL-TIME DISPLAY			
Summary table of main electric parameters	•	•	•
Voltage/current waveforms			
Tables or histograms of Harmonics and THD%			
Voltage/current vector diagram			
Polarization Index (PI)		•	
Dielectric Absorption Ratio		•	
Ground fault location		•	

Instruments

Photovoltaic Instrument - Selection Guide



ADDITIONAL CHARACTERISTICS	SOLARIV	PVISOTEST	PVCHECK
Measuring range of I-V Curve / IVCK	1500V/10A 1000V/15A		1000V/15A only VOC and ISC
Measuring range for efficiency measurement	1000V DC/ 265V AC	1000V AC-DC 3000A	
Touchscreen colour display		•	
LCD display with backlight	•		•
USB port for data download onto Pen Drive		•	
PC interface with software for Windows	•	•	•
Integrated WiFi interface	•		
Custom management of internal PV module database	•		•
Power supply: Rechargeable battery, charger		•	
Indication of recording duration for efficiency measurement	•	•	
On display help	•	•	•
Safety category			
Reference standard for safety	IEC/EN61010-1	IEC/EN61010-1	IEC/EN61010-1
Reference standard for Power Quality Analysis		EN50160	
Dimensions (mm) LxWxH	235x165x75	235x165x75	235x165x75
Weight (batteries included) kg	1.2	1	1.2

Solutions for Performance Optimization and Troubleshooting

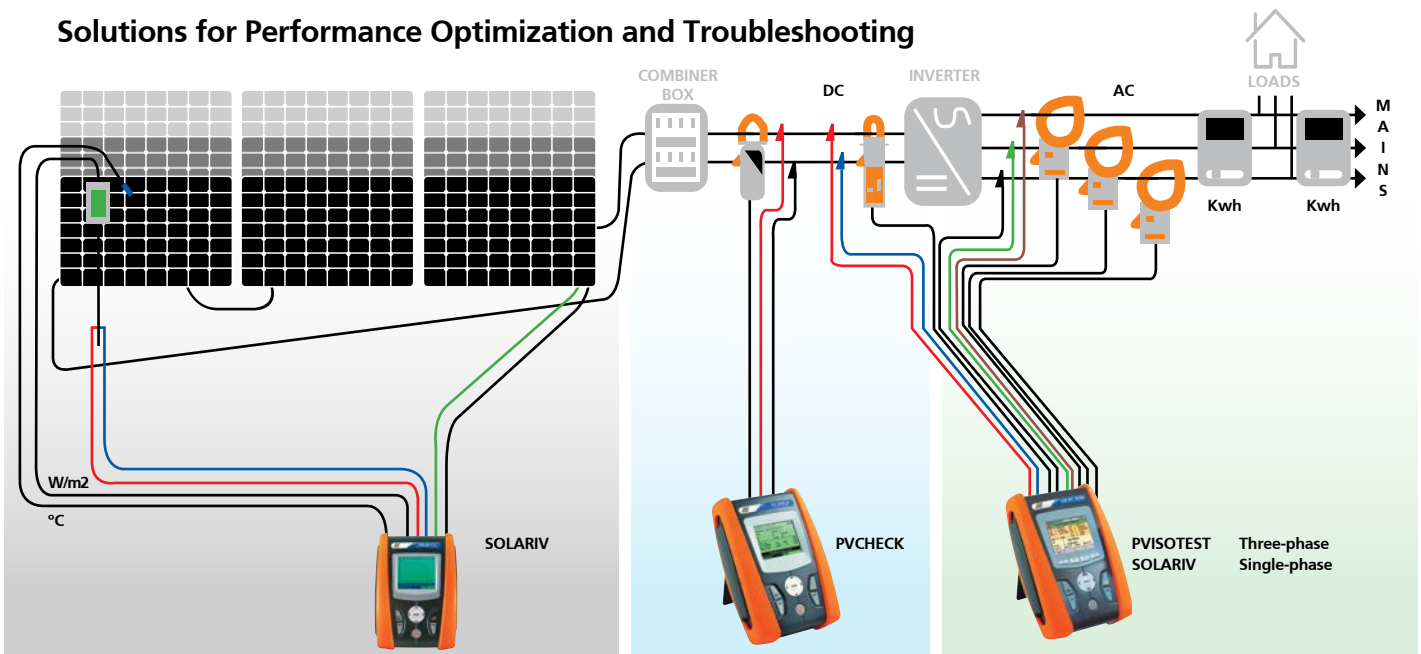

Troubleshooting

Possibly during the operation of a system, some modules may jeopardise the performance of the whole system. When system efficiency is lower than expected, it is necessary to detect the defective modules so that they can be replaced.

Suggested solution: Measure the I-V curve with SOLARIV (p30) (DC voltage up to 1500V).

Commissioning Tests

When operating a photovoltaic system, it is necessary to certify its safety according to IEC62446.

Suggested solution: PVCHECK (p32) is recommended to perform these verifications.

Performance

For effective maintenance programmes, Performance Recording and monitoring is necessary to identify losses quickly and efficiently.

Suggested solution: PVISOTEST (p31) or SOLARIV (p23) are ideal for recording utilisation over time as well as performance checks of an inverter.

Instruments

Photovoltaic Instrument Accessories - Selection Guide



ACCESSORY		Description	SOLARIV	PVISOTEST	PVCHECK
PAGE NO.			30	31	32
TOPVIEW2006		PC Windows software + USB/ optical cable (C2006) for TOPVIEW2006	TOPVIEW2006	TOPVIEW2006	TOPVIEW2006
TOPVIEW2007		(C2007) for TOPVIEW2007			
PT300N		PT1000 probe for PV module temperature	•		○
SOLAR02		Irradiation and Temperature Remote unit	•		○
KITGSC4		4 Cables, 4 Crocodile clips	•	•	•
TKIT800		5 Cables, 5 Crocodile clips			
KITPVMC3 - KIT-PCMC3		2 Adapters with connectors MC3	KITPVMC3		KITPCMC3
KITPVMC4 - KITPCMC4		2 Adapters with connectors MC4	KITPVMC4	KITPCMC4	KITPVMC4
A0055		AC/DC Battery charger 230V 50/60Hz			
PT400		Touch-screen pen			
HT304N		Irradiation measurement sensor	•		○
M304		Mechanical inclinometer	•		○
HT4004N		Standard 10-100A DC clamp, diameter 32mm	•		
HT4005K		Standard 200A AC clamp, diameter 40mm	•		
C2007		TYPE A/B 1.5m USB cable			
C2006		USB cable with optional adapter	•		•
HT97U		Standard 10-100-1000A AC clamp, diameter 54mm	○		
HTFLEX33E		Flex 3000A AC clamp, diameter 174mm			
HP30D1		1000A DC clamp, diameter 83mm	○		
HP30C3		3000A AC clamp, diameter 70mm	○		
HP30C2		200-2000A AC clamp, diameter 70mm	○		
606IECN		Magnetic connectors for voltage measurement	○	○	○
BORSA2051		Soft carrying bag			•
VA500		Rigid carrying case	•		
KITKELVIN		Test lead kit	○		

○ Optional



CAT II 1000V DC

CAT III 300V AC to ground (Max 1500V among inputs P1, P2, C1, c2)



Model Specification

Power Source	6x1.5V AA Alkaline Batteries
Standard Accessories Selection Guide	<p>SOLAR02 - Irradiation and Temperature Remote</p> <p>KITGSC4 - 4 x Cables & 4 x Crocodile Clips</p> <p>KITPVMC3 - 2 x Adapters with Connectors MC3</p> <p>KITPVMC4 - 2 x Adapters with Connectors MC4</p> <p>HT4005K - Standard 200A AC clamp, diameter 40mm</p> <p>HT4004N - Standard 10-100A DC Clamp, Diameter 32mm</p> <p>HT304N - Sensor for Irradiation Measurement</p> <p>PT300N - PT1000 Probe for PV Modules Temperature</p> <p>M304 - Mechanical inclinometer</p> <p>TOPVIEW2006 - Windows Software & Optical/USB C2006 Cable</p> <p>VA500 - Rigid Case</p>
Certificates	IEC/EN61010-1, Calibration Certificate

I-V CURVE TRACER UP 1500V DC

SOLARIV

- Measurement of PV module/string output voltage, 1500V
- Measurement of PV module/string output current, 15A
- Resolution (spots) of I-V curve in Standard or Capacitive mode, 128
- Measurement of Voc-Isc-Pmax-Vmpp-Impp-Fill Factor
- Measurement of cell temperature through external feeler
- Measurement of irradiation [W/m²] through reference cell
- Measurement of DC and rated power at module/string output
- Detection of I-V curve through remote unit SOLAR-02
- Measurement of resistance of series Rs of panels
- Direct comparison with reference conditions (STC - 1000W/m², 25°C)
- Internal database for managing up to 30 PV modules (30.000 modules by software)
- DC/AC TRMS single-phase voltage
- DC/AC TRMS single-phase current
- Single-phase DC power / AC active power
- Solar irradiation [W/m²] with reference cell HT304N
- Panel and environmental temperature through probes
- Remote unit SOLAR02 with RF connection
- Display of environmental data in real time
- Use of compensation relationships Cells/ Environment on Pdc
- Parameter recording of a PV system with 5s to 60min programmable IP
- Max/Min

Technical Overview

Certifier of Single Phase PV Installation

Feature	Parameter	Accuracy
DC Voltage (V)	15 – 1500V	±0.5% + 2 Digit
AC TRMS Voltage (V)	10 – 265V	±0.5% + 2 Digit
DC Current (External Transducer Clamp(mV))	-1100 - 1100mV	±0.5% + 0.6mV
AC TRMS Current (External Transducer Clamp (mV))	1 – 1200mV	±0.5% + 0.6mV
DC Power (1<FS≤1000)	0 – 9999kA	±0.7% + 3 Digit (I _{meas} < 10%FS)
AC Single Phase (1<FS≤100)	0 – 9999kA	±0.7% +3 Digit (I _{meas} < 10%FS)
Frequency (Hz)	47.5 – 63Hz	0.2% + 1.0Hz
Irradiance (Reference Cell)	1 – 65mV	±1.0% + 5 Digit
Temperature (External Probe PT1000)	-20 to +100°C	±1.0% +1°C

I-V Curve and IVCK Measurements

Feature	Parameter	Accuracy
I-V, IVCK: VDC Voltage @ OPC	15 – 1499.9V	±0.5% + 2 Digit
I-V, IVCK: IDC Current @ OPC	10 – 15A	±1.0% + 2 Digit
I-V: DC Power @ OPC (Vmpp >30V, Impp >2A)	50 – 99 999W	±1.0% + 6 Digit
I-V, IVCK: VDC Voltage (@ STC)	5 – 999.9V	±4.0% + 2 Digit
I-V: IDC Current (@ STC)	10 – 99A	±4.0% + 2 Digit
I-V: DC Power @ STC (Vmpp >30V, Impp >2A)	50 – 99 999W	±5.0% + 1 Digit

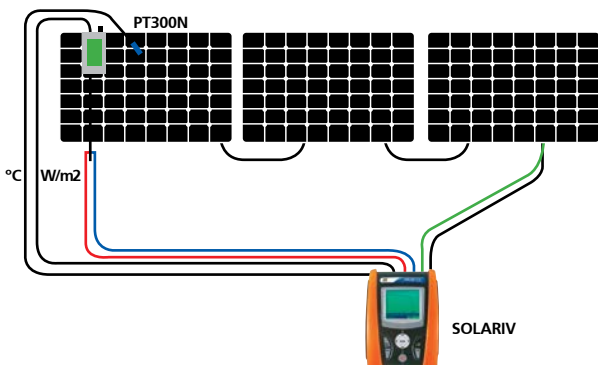

Measuring of curve IV with environmental sensors

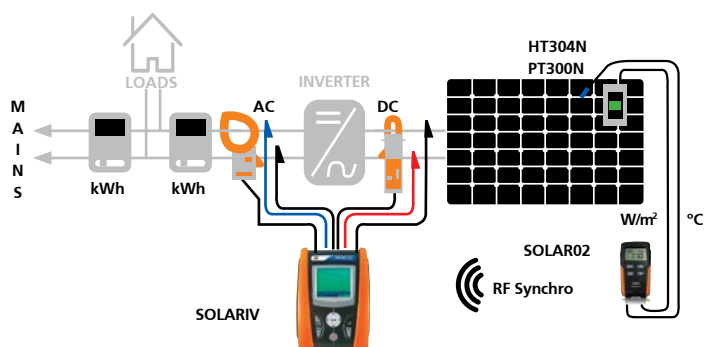

Measuring single-phase efficiency with remote environmental sensors



IP40

CAT III 1000V (AC)

CAT III 1500V (DC)



KITGSC4



KITPCMC4



VA507



SP-5100



TOPVIEW2006

PV Insulation Tester

PVISOTEST

Multifunction device for checking electric safety and performance of a photovoltaic system.

Features

- Insulation measurement up to 1 500V DC even on live systems
- Ground Fault Locator function for localization of the faulty module
- Continuity of the protective conductor with 200mA
- Dielectric absorption ratio D.A.R
- Measurement of polarization index P.I.
- Backlit Display 128 x 128 pixels
- Optical/USB interface

Technical Overview

Feature	Parameter	Resolution	Accuracy
DC Voltage (V)	3 - 1500V	1	±1.0% +2 Digit
AC Voltage (V)	3 - 1000V	1	±1.0% +3 Digit
Insulation Test Voltage (V)	250V/ 500V/ 1000V/ 1500V		
Insulation Resistance (MΩ)	0.01 - 9.99MΩ	0.01	±5.0% +5 Digit
	10 - 99.9MΩ	0.1	
Continuity of protection conductors (RPE)	0.00 - 9.99Ω	0.01	±2.0% +2 Digit
	10 - 99.9Ω	0.1	
	100 - 1999Ω	1	
Ground Fault Locator (GFL) function	0.1 - 0.99MΩ	0.01	±5.0% +5 Digit (±1 module)
	1.0 - 19.9MΩ	0.1	
	20 - 100MΩ	1	
Working Humidity	<80%RH		
Working Temperature	0°C to 40°C		
Memory	999 tests MAX		
Display	128 x 128 pixel with backlight		

Model Specification

Power Source	6 x 1.5V AA Batteries
Dimensions (mm)	235(L) x 165(W) x 75(H)
Weight (g)	1200 (including batteries)
Standard Accessories Selection Guide	KITGSC4 - 4 x Cables & 4 x Crocodile Clips KITPCMC4 - 2 x MC4 banana adapters VA507 - Hard carrying case SP-5100 - Carrying straps TOPVIEW2006 - Windows Software & Optical/USB C2006 Cable, user manual on CD-ROM
Certificates	IEC/EN61010-1, IEC/EN61010-2-030, IEC/EN61010-2-033, IEC/EN61010-2-034

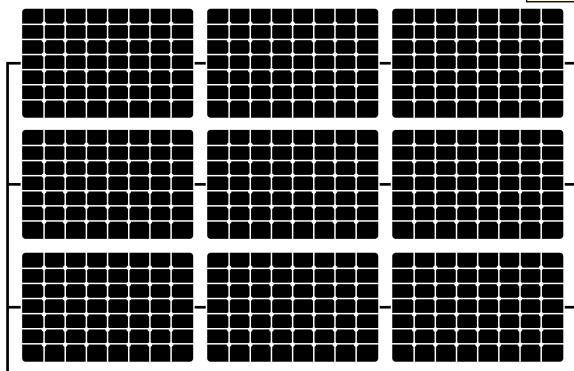

Insulation mode DUAL
Unearthed PV field

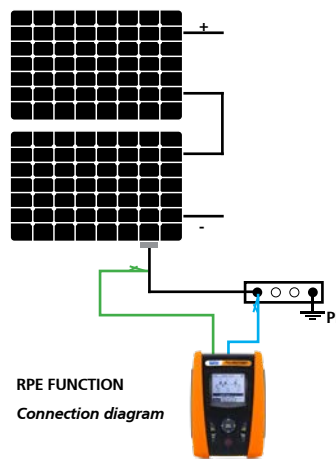

RPE FUNCTION
Connection diagram

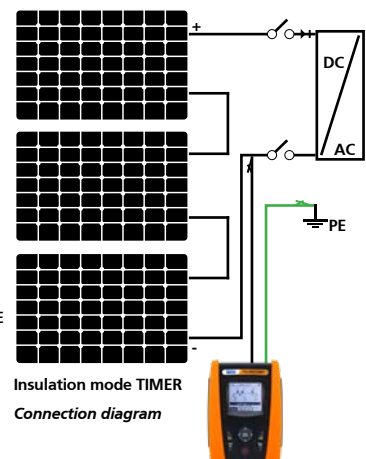

Insulation mode TIMER
Connection diagram



PVCHECK PRO



to ground (Max 1000V DC among inputs P, N, E, C)

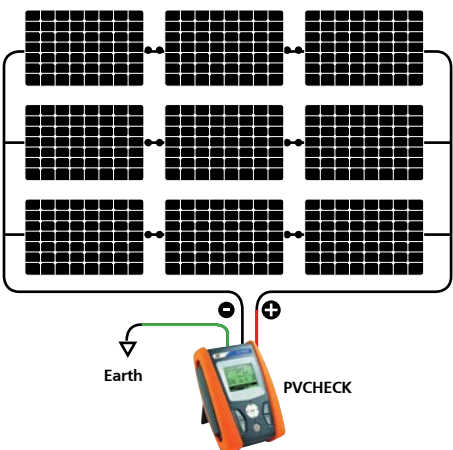

"Whole photovoltaic field" insulation measurement method

Multifunction Device for Commissioning Tests

PVCHECK/ PVCHECKPRO

- Continuity of protective conductors with test current 200mA
- Insulation measurement with test voltage 250,500 and 1000VDC
- Open-circuit voltage (VOC) measurement up to 1000V DC
- Short-circuit current (ISC) measurement up to 15A DC
- DC voltage - DC current - DC power measurement
- Use of compensation relationships Cells/Environment on Pdc
- Internal database for managing up to 30 PV modules (30.000 modules by software)
- Test measurement of string operation
- Result for every measurement OK/NO
- Internal memory and optical USB output for PC connection (256kBytes)
- LCD display, 128x128pxl, with backlight

Technical Overview

Performance Test

Feature	Parameter	Accuracy
DC Voltage (V)	5 – 999.9V	±1.0% + 2 Digit
DC Current (Mean External Clamp (mV))	0 – 1000V	±0.5% + 0.6mV Digit
DC Current (FS DC clamp [A])	1<FS≤1000	0.05 – 5A
DC Power (Vmeas > 150V)	1<FS≤1000	±1.5% +3 Digit (Imeas < 10%FS)

Functionality Test

Feature	Parameter	Accuracy
DC Voltage @ OPC (V)	5 – 999V	±1.0% + 2 Digit
DC Current @ OPC (A)	0.1 – 15A	±1.0% + 2 Digit
DC Voltage @ STC (V)	5 - 999	±4.0% + 2 Digit
DC Current @ STC (A)	0.1 – 15A	±4.0% + 2 Digit
Irradiance (Mean HT304N) (mV)	1 – 40mV	±1.0% + 0.1mV
Temperature (Mean PT300N) (°C)	-20 to +100°C	±1.0% + 1°C

Safety Test

Feature	Parameter	Accuracy
Continuity Test (LOWΩ)	0 – 199Ω	±2.0% + 2 Digit
Insulation TEST (MΩ) – Mode TIMER	25/ 500/ 1000V 0.01 – 199MΩ	±5.0% + 5 Digit

Model Specification

Power Source	6x1.5V AA Alkaline Batteries
Standard Accessories Selection Guide	KITGSC4 - 4 x Cables & 4 Crocodile Clips KITPCMC3 - 2 x Adapters with MC3 Connectors KITPCMC4 - 2 x Adapters with MC4 Connectors HT4004 - Standard 10-100A DC clamp, diameter 30mm TOPVIEW2006 - Windows Software & USB C2007 Cable BORSA2051 - Soft Carrying Bag
Optional Accessories Selection Guide	PT300N - PT1000 Probe for PV Modules Temperature SOLAR02 - Irradiance and Temperature Remote HT304N - Sensor for Irradiance Measurement M304 - Mechanical inclinometer
Certificates	IEC/EN61010-1, Calibration Certificate

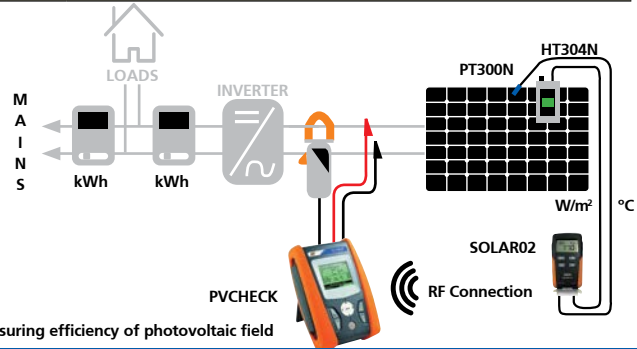

Measuring efficiency of photovoltaic field



IP40

CAT III 1000V
to ground

CAT IV 600V

AC/DC TRMS Thermal Clamp 1500V DC

ECLIPSE

- Jaw size: 40mm
- Detects AC voltage without contact
- Data logger and graph
- Diode test
- Bluetooth connectivity with HTMercury APP
- Laser pointer
- White LED illuminator

Technical Overview

Feature	Parameter	Accuracy
DC Voltage (V)	600mV/ 6/ 60/ 600/ 1500V	±0.8% + 5 Digit
AC TRMS Voltage (V)	6/ 60/ 600/ 1000V	±2.5% + 5 Digit
AC+DC TRMS Voltage (V)	6/ 60/ 600/ 1000V	±2.5% + 20 Digit
DC Current (A)	60/ 600/ 1000A	±2.0% + 8 Digit
AC TRMS Current (A) INRUSH Current	60/ 600/ 1000A	±2.5% + 5 Digit
AC TRMS Current (A) with Flexible clamp	30/ 300/ 3000A	±3.0% + 5 Digit
Resistance (Ω)	600/ 6kΩ/ 60kΩ/ 600kΩ/ 6MΩ/ 60MΩ	±1.0% + 10 Digit
Frequency (Hz)	40 – 10kHz	±0.09% + 5 Digit
	60/ 600/ 6kHz/ 60kHz/ 600kHz/ 6MHz/ 10MHz	±0.2% + 5 Digit
Temperature (°C) K-Type	-40 to +1000°C	±1.5% + 3°C
Capacitance (F)	60nF/ 600nF/ 6μF/ 60μF/ 600μF/ 6000μF / 60mF/ 100mF	±3.0% + 8 Digit
Colour TFT Display		6 000 Counts

Infrared Temperature

Feature	Parameter	Accuracy
Temperature (°C)	-20 to +260°C	±3°C or ±3% (@ env temp: 10 - 35°C, object temp >0°C)
Thermal sensitivity	<0.1°C @ 30°C / 100mK	
Colour palettes	5 (Iron, Rainbow, Grey, Reverse Grey, Feather)	
Field of View (FOV)	21° x 21° / 7.5mm	
IFOV (@1m)	4.53mrad	
Image frequency	50Hz	
IR Sensor Resolution	80 x 80pxl,	
Emissivity correction	0.01 to 1.00	
Measurement cursors	3 (FIXED, MAX, MIN)	
Focusing	Automatic	



F3000U



AOMCY



Test Leads



TBMTEMPROBE

Model Specifications

Power Source	1 x 7.2V Li-ION Rechargeable Battery (1200mAh)
Standard Accessories	Test Leads, Micro SD Card (8GB Card) K-Type Temperature Probe (TBMTEMPROBE), Pouch
Optional Accessories	Flexible Clamp (F3000U), 400A Clamp (HT4006)
Certificates	IP40, IEC/EN61010-1, IEC/EN61326-1
Dimensions (mm):	190(L) x 75(W) x 55(H)
Weight (g)	555



TBM089 - 1000A AC/DC

- Jaw size: 51mm
- 3-Phase rotation for mains and motors
- AmpTip™
- Non-contact EF detection (NCV)
- Rotary selector switch
- Continuity test
- Flashlight

Technical Overview

Feature	Parameter	Accuracy
DC Current (A)	60/ 600/ 1000A	±1.8% + 5 Digit
AC Current (A)	60/ 600/ 1000A	±1.8% + 5 Digit
DC Voltage (V)	600/ 1000V	±1.0% + 5 Digit
AC Voltage (V)	600/ 1000V	±1.2% + 7 Digit
Resistance (Ω)	600/ 6kΩ/ 60kΩ	±1.0% + 5 Digit
Temperature (°C)	-40 to +400°C	±1.0% + 0.8°C
Frequency (Hz)	5Hz - 400kHz	±0.5% + 4 Digit
Capacitance (F)	2500µF	±2.0% + 4 Digit
Display	3 ⁵ / ₆ Digits	6 000 Counts



LIFETIME WARRANTY

CAT IV 1000V

Model Specification

Power Source	2 x 1.5V AA Batteries
Standard Accessories	Carry Pouch, Temp Probe TBMTEMPPROBE , Test Leads, Crocodile Clips
Certificates	UL, IEC61010-1, Certificate of Conformance



CAT III 1500V (DC)
CAT IV 1000V (AC/DC)



Multimeter Clamp PV

TBM198PV

- Jaw size: 55mm
- VFD-V, VFD-Hz (Variable frequency drivers)
- Update rate: 5 per second
- Ghost-Voltage-Buster
- Backlit Dual display
- Non-contact EF detection (NCV)
- Data logging (PC-Comm interface)
- 5mS Crest-Max capture mode
- Auto Ranging Relative-Zero mode

Technical Overview

Feature	Parameter	Accuracy
AC Current (A)	0 – 2000A	±3.5% ± 5 Digit
DC Current (A)	0 – 2000A	±3.0% ± 5 Digit
DC + AC Current (A)	0 – 2000A	±3.5% ± 8 Digit
AC Voltage (V)	6/ 60/ 600/ 1000V	±1.2% ± 5 Digit
DC Voltage (V)	6/ 60/ 600/ 1000V / 1500V	±0.5% ± 5 Digit
AC+DC Voltage (V)	6/ 60/ 600/ 1000V	±1.4% ± 7 Digit
Capacitance (F)	60nF/ 600nF/ 6µF/ 60µF/ 600µF/ 2000µF	±4.0% ± 5 Digit
Resistance (Ω)	600/ 6k/ 60k/ 600k/ 6M/ 40MΩ	±2.3% ± 5 Digit
Diode Tester	1V	1.0% ± 3 Digit
Temperature (°C)	-50°C to +1000°C	±0.3% ± 4 Digit
Input impedance	10MΩ	
Display	3 ¹ / ₆ Digits	6 000Counts (+1999 dual display)

Model Specifications

Power Source	2 x 1.5 AA Batteries
Standard Accessories	Test Leads, K-Type Thermocouple TBMTEMPPOBE , Soft Carrying Pouch
Optional Accessories	USB interface kit TBU19X ;
Certificates	IEC/EN/BSEN/CSA_C22.2_No./UL standards of 61010-1 Ed. 3.1, 61010-2-032 Ed. 4.0, 61010-2-033 Ed. 2.0
Dimensions (mm)	264(L) 97 (W) x 43(H)
Weight (g)	608



Thermal Multimeter

MERCURY

- Open-circuit string voltage (Voc)
- String operating voltage (Vmpp)
- Current provided by string in operating conditions (Impp) readings do not differ by $\geq 5\%$ from string to string
- Status of filter capacitors found in inverter (one of the most critical elements)
- Status of locking and by-pass diodes
- Thermographically analyse photovoltaic modules to search for presence of overheated modules or cells

Technical Overview

Feature	Parameter	Accuracy	Overload Protection
AC-DC TRMS Voltage (V)	6, 60, 600, 1 000	$\pm 2.4\%$ +20dgt	1 000V DC/AC rms
AC, AC+DC TRMS Current* (A)	1 000m, 10, 40, 100, 400, 1 000A	$\pm 2.4\%$ +5dgt	1 000V DC/AC rms
Duty Cycle	5%	$\pm 1.2\%$ +2dgt	1 000V DC/AC
Resistance & Continuity (Ω) Buzzer <50 Ω	600, 6k, 60k, 600k, 6M, 60M Ω	$\pm 2.5\%$ +20dgt	1 000V DC/AC
Capacitance (F)	60n, 600n, 6 μ , 60 μ , 600 μ , 6 000 μ F	$\pm 2.5\%$ +20dgt	1 000V DC/AC
Temperature Type-K ($^{\circ}$ C)	-40 to +600 $^{\circ}$ C 600 to +1 000 $^{\circ}$ C	$\pm 1.5\%$ +3 $^{\circ}$ C	1 000V DC/AC

Infrared Temperature

Feature	Parameter	Accuracy
IR Sensor Resolution (pxl)	80x80pxl (34 μ m)	
Spectrum Range	8-14 μ m	
IFOV (@1m)	4.53mrad	
Thermal Sensitivity	0.1 $^{\circ}$ C @ 30 $^{\circ}$ C/100mK	
Min Focusing Distance (m)	0.5m	
Temperature ($^{\circ}$ C)	-20 to +260 $^{\circ}$ C	$\pm 3\%$ +3 $^{\circ}$ C
Colour Palettes	4 (Iron, Rainbow, Grey, Grey Inverted)	



F3000U



AOMCY



Test Leads



TBMTEMPROBE

Model Specifications

Power Source	2x rechargeable Li-ION batteries.
Standard Accessories	Test Leads, K-Type Temperature Probe (TBMTEMPROBE), Micro SD Card (8GB), Flexible Clamp (F3000U), Pouch
Optional Accessories	AC Clamp (HT97U)
Certificates:	IEC/EN61010-1, EMC: IEC/EN 61326-1
Dimensions (mm)	185 (L) x 75(W) x 55(H)
Weight (g)	55 (including batteries)



HellermannTyton



www.shop.hellermanntyton.co.za

Johannesburg
Tel: (011) 879 6620

Durban
Tel: (031) 492 0481

Cape Town
Tel: (021) 594 7100

Gqeberha (PE)
Tel: (041) 408 2400

Email
sales.jhb@hellermann.co.za

Website
www.hellermanntyton.co.za