



2.1	TOOL KITS	
	- Backpacks and Tool Kits	97-100
	- Tool Bags	101-102
2.2	CRIMPING TOOLS	
	- Light Duty	103-106
	- PV	106
	- Medium Duty	107-108
	- Heavy Duty	108-109
	- Hydraulic and Kits	110-112
	- Rotational Punch Kits	113
	- Hydraulic Pumps and Crimp Heads	114
	- Hydraulic Cable Cutting and Crimping Heads	115
2.3	CUTTERS	
	- Cable Cutters	116
	- Ratchet Cable Cutter, Core Cutter and Pipe Cutter	117
2.4	- Pliers and Cutters	118-119
	- Wire Strippers and Aviation Tin Snips	119
	- Cutters and Pliers 1000V	120
2.5	- Strippers and Cutters	121
	- Utility Knives and PVC Pipe Cutter	122
	- Hacksaws and Blades	123-124
2.6	PUNCHES AND HOLESAWS	
	- Chassis Punch	125
	- Tungsten Holesaws and Kit	125
	- Bi-metal Holesaws and Kits	126
2.7	TOOLS	
	- Screwdrivers	127
	- Socket Wrench Set	128
	- Vice Grips	129
	- Adjustable Spanner	129
	- Combi Wrenches	129
	- Universal Key	130
	- Allen Key Sets	130
	- Fish tapes	130
	- Tape Measures	131
	- Tool Box	131
	- Ball Pein Hammer	131
2.8	- IEC Insulated Range 1000V	132-135
2.9	- Soldering Irons and Gas	136
2.10	CABLE TIE TENSIONING TOOLS	
	- Nylon and Selection Guide	137-138
	- Stainless Steel and Selection Guide	138
	- Cable Tie Selection Chart	139-140
2.11	- Heat Guns	141-142
	- Heat Gun Accessories - Selection Guide	142
	- Glue Gun	143
	- Glue Stick - Selection Guide	143
2.13	MISCELLANEOUS TOOLS	
	- Torches	144



PVBP - Solar Tool Backpack

- Suitable for harsh and demanding environments including solar
- Conforms to safety standards
- Backpack is water resistant
- Quality tools with lifetime warranty
- Weight: 8kg (Max weight capacity 12kg)
- 1000V insulated tools included



Code	Description
AW150	Wrench Adjustable 150mm
CC22	Cable Cutter Copper and Aluminium 25mm,
H015	Junior Hacksaw (Blade length 150mm)
HAMP300	Ball Pein Hammer 300g
HT100205	1000V Insulated Combination Plier 205mm
HT104200	1000V Insulated Long Nose Plier 200mm
HT112180	1000V Insulated Diagonal Cutter 180mm
HT20013	1000V Insulated Open-Ended Spanner 13mm
HT21014	1000V Insulated Ring Spanner 14mm
INSSET	8 Piece 1000V Insulated Screwdriver Set including Neon Voltage Tester 
O1604LM	7 Piece Allen Key Set 2.5-10mm
PVCT46	Crimper 2.5 - 6mm, solar cable
PVST46	Solar Cable Stripper 2.5 - 6mm,
HYAC5	Crimp Tool Bootlace 0.5 - 6mm,
HD16L	Crimper 1.5 - 16mm,
HUK1	Universal Panel Key
SW10	Socket Driver 10mm
TOOLBAGBP	Bag dimensions (mm): 460(H) x 380(W) x 210(D)

ELECBP - Electrician's Tool Backpack: 32 Piece

- Suitable for harsh and demanding environments
- Conforms to safety standards
- Backpack is water resistant
- Quality tools with lifetime warranty
- Weight: 8kg (Max weight capacity 12kg)



Code	Description
AW200	Adjustable Spanner 200mm
CC38	Cable Cutter 38mm ²
ECOSSET	7 Piece 1000V Insulated Screwdriver Set with Neon Voltage Tester 
H015	Junior Hacksaw Blade length 150mm
HAMP300	Ball Pein Hammer 300g
HT16UT	Crimper 1.5-16mm,
HEADLIGHT	LED Headlight
HUK1	Universal Panel Key
LGJ250	Groove Joint Plier 250mm
LGJ300	Groove Joint Plier 300mm
MHT5	5m Magnetic Tip Tape Measure
O1604LM	7 Piece Allen Key Set 2.5-10mm,
SDC200	Diagonal Cutter 200mm
SEP200	Combination Plier 200mm
SLN160	Long Nose Plier 160mm
SVN160	Wire Stripper 160mm
SW10	Socket Driver 10mm
SW8	Socket Driver 8mm
VG250	Vice Grip 250mm
WAK2	Manual Retractable Utility Knife (Blade length 60mm)
TOOLBAGBP	Bag dimensions (mm): 460(H) x 380(W) x 210(D)



LIFETIME WARRANTY

ELBKBP - Electrician's Tool Backpack: 20 Piece

- Conforms to safety standards
- Quality tools with lifetime warranty
- Weight: 8kg (Max weight capacity 12kg)

Code	Description
AW200	Adjustable Spanner 200mm
CC38	Cable Cutter 38mm ²
ECOSSET	7 Piece 1000V Insulated Screwdriver Set with Neon Voltage Tester
H015	Junior Hacksaw Blade length 150mm
HAMB300	Ball Pein Hammer 300g
HEADLIGHT	LED Headlight
HUK1	Universal Panel Key
MHT5	5m Magnetic Tip Tape Measure
SDC200	Diagonal Cutter 200mm
SEP200	Combination Plier 200mm
SLN160	Long Nose Plier 160mm
SVN160	Wire Stripper 160mm
VG250	Vice Grip 250mm
WAK2	Manual Retractable Utility Knife (Blade length 60mm)
TOOLBAGBP	Bag dimensions (mm): 460(H) x 380(W) x 210(D)

ELECKT - Electrical Tool Kit: 16 Piece

- Quality tools with lifetime warranty
- Digital multimeter
- General purpose



LIFETIME WARRANTY

*Tools only

Codes	Description
AW200	Adjustable Spanner 200mm
CCMP	Indent Crimper 0.5 - 10mm
ECOSSET	7 Piece 1000V Insulated Screwdriver Set including Neon Voltage Tester
HEADLIGHT	LED Headlight
O9FA	Allen Key 1.5 - 2 - 2.5 - 3 - 4 - 5 - 5.5 - 6 - 8
SDC180	Diagonal Cutter 180mm
SEP180	Combination Plier 180mm
SLN160	Long Nose Plier 160mm
T235H	TRMS Digital Multimeter - 1999 Counts
WAK2	Manual Retractable Utility Knife (Blade length 60mm)
TOOLBAGELEC	Bag dimensions (mm): 380(H) x 240(W)

PROKT - Electrician's Tool Kit: 17 Piece

- Quality tools with lifetime warranty
- VDE 1000V tools
- Digital clamp meter



LIFETIME WARRANTY

*Tools only

Code	Description
AW200	Adjustable Spanner 200mm
CC22	Cable Cutter 22mm ²
CCMP	Indent Crimper 0.5 - 10mm
HEADLIGHT	LED Headlight
HUK1	Universal Panel Key
INSSET	8 Piece 1000V Insulated Screwdriver Set including Neon Voltage Tester
SEP180	Combination Pliers 180mm
SLN160	Long Nose Plier 160mm
TBM031	600A AC Clamp Meter
WAK2	Manual Retractable Utility Knife (Blade length 60mm)
TOOLBAGP	Bag dimensions (mm): 380(H) x 240(W)



LIFETIME WARRANTY*
*Tools only

PK1000V - Electrical Tool Kit 1000V: 18 Piece

- Quality tools with lifetime warranty
- All tools and multimeter can be purchased individually

Code	Description
45092	Stripmaster 0.75-6mm,
AW200	Adjustable Spanner 200mm
CC38	Cable Cutter 38mm ²
HCP200H	1000V Plier 200mm
HDC205H	1000V Diagonal Cutter 200mm
HLN200	1000V Long Nose Plier 200mm
HUK1	Universal Panel Key
INSSET	8 Piece 1000V Insulated Screwdriver Set with Neon Voltage Tester
LEDTORCH	LED Weatherproof Torch
T235H	TRMS Digital Multimeter – 1999 Counts
WAK2	Manual Retractable Utility Knife (Blade length 60mm)
PCS	Bag dimensions (mm): 390(L) x 240(W)

ECONOKIT - Electrician's Tool Kit: 22 Piece

- Quality tools with lifetime warranty
- All tools and multimeter can be purchased individually



LIFETIME WARRANTY*
*Tools only

Code	Description
8325	Joint Pliers 250mm
AW200	Adjustable Spanner 200mm
CC22	Cable Cutter 22mm ²
CCMP	Indent Crimper 0.5 - 10mm,
ECOSSET	7 Piece 1000V Insulated Screwdriver Set with Neon Voltage Tester
H015	Junior Hacksaw (Blade length 150mm)
HUK1	Universal Panel Key
LEDTORCH	LED Weatherproof Torch
MHT5	5m Magnetic Tip Tape Measure
H100A	Hacksaw (Blade length 300mm)
SDC200	Diagonal Cutter 200mm
SEP200	Combination Plier 200mm
SLN200	Long Nose Plier 200mm
SVN160	Wire Stripper 160mm
T235H	TRMS Digital Multimeter – 1999 Counts
WAK2	Manual Retractable Utility Knife (Blade length 60mm)
TOOLBAGM	Bag dimensions (mm): 430(L) x 340(W)

TECHKT - Technical Tool Kit: 19 Piece

- Quality tools with lifetime warranty
- Digital multimeter
- General purpose



LIFETIME WARRANTY*
*Tools only

Code	Description
AW200	Wrench Adjustable 100mm
CC22	Cable Cutter 25mm
CCMP	Indent Crimper 0.5 - 10mm
ECOSSET	7 Piece 1000V Insulated Screwdriver Set with Neon Voltage Tester
HUK1	Universal Panel Key
MHT5	5m Magnetic Tip Tape Measure
O9FA	Allan Key (1.5 - 2 - 2.5 - 3 - 4 - 5 - 5.5 - 6 - 8mm)
SEP180	Combination Plier 180mm
SLN160	Long Nose Plier 160mm
SVN160	Wire Stripper 160mm
TSPAN810	Tube Spanner 8, 10mm
T235H	Digital Multimeter - 1999 Counts
WAK2	Manual Retractable Utility Knife (Blade length 60mm)
TOOLBAGTECH	Bag dimensions (mm): 380(L) x 240(W)

ELECMINI – Mini Tool Kit: 14 Piece

- Quality tools with lifetime warranty
- All tools can be purchased individually



LIFETIME WARRANTY*
*Tools only

Code	Description
AW150	Adjustable Spanner 150mm
ECOSSET	7 Piece 1000V Insulated Screwdriver Set with Neon Voltage Tester
HEADLIGHT	LED Headlight
HUK1	Universal Panel Key
SDC160	Diagonal Cutter 160mm
SEP160	Combination Pliers 160mm
SLN160	Long Nose Plier 160mm
WAK2	Manual Retractable Utility Knife (Blade length 60mm)
	Bag dimensions (mm): 300(L) x 180(W) with external zip up pouch

TOOLBAGBP

- Bag dimensions (mm): 460 (H) x 380 (W) x 210 (D)
- Weight: 8kg (Max weight capacity 12kg)
- **PVBP** (p97), **ELECBP** (p97), **ELBKB** (p98)

**TOOLBAGL**

- Bag dimensions (mm): 460(H) x 360(W)
- Inside: 2 internal compartments - 15 pouches
- Outside: 3 pouches
- Hacksaw compartment
- Multimeter pouch
- Strap with steel buckle
- Tool configurations can be made up according to customer specifications

**TOOLBAGM**

- Bag dimensions (mm): 480(H) x 340(W)
- Inside: 11 pouches
- Outside: 3 pouches and Multimeter pouch
- Hacksaw compartment
- Strap with steel buckle
- Tool configurations can be made up according to customer specifications
- **ECONOKIT** (p99)

**TOOLBAGP**

- Bag dimensions (mm): 380(H) x 240(W)
- Inside: 14 elastic straps
- 2 pouches
- **PROKT** (p98)

**TOOLBAGELEC**

- **ELECT** p98)

**TOOLBAGTECH**

- **TECHT** (p100)



TMULTCSE - Multimeter Carry Pouch

- General purpose
- Dimensions (mm): 250(L) x 150(W) x 60(H)



DUSPOLABAG

- DUSPOLA (p56)
- DUSPOLE (p56)
- Dimensions (mm): 300(L) x 120(W) x 50(H)



VA500/VA502 - Hard Carry Case

- Protects devices from water, dust and hostile environments
- Space for accessories



Does not include instrument

LY2001 - Crimper: Pre-Insulated Terminals (DIY)



- Cutting, crimping and stripping
- Light duty

Crimping Range (mm ²)	
0.75 - 1	■
1.1 - 2.5	■
4 - 6	■



HYT1 - Crimper: Pre-Insulated Terminals (DIY)



- Ratchet release
- Dimensions (mm): 254(L) x 66(W)

Crimping Range (mm ²)	
0.5 - 1	■
1.1 - 2.5	■
4 - 6	■



HYT7 - Crimper: Pre-Insulated Terminals



- Double crimp grip
- Adjustable crimping pressure
- Ratchet release
- Tension adjustable
- Dimensions (mm): 229(L) x 70(W)

Crimping Range (mm ²)	
0.5 - 1	■
1.1 - 2.5	■
4 - 6	■



KST2000A/KST2000B - Crimper: Insulated Terminals



- Ratchet release (KST2000B)
- Ring, Space, Pin and Twingrip (KST2000B)
- Dimensions (mm): 267(L)

Crimping Range (mm ²)	
0.5 - 1.25	■
1.1 - 2	■
4 - 5.5	■



HS2004 - Crimper: Insulated Terminals (DIY)



- Cutting, crimping and stripping
- Insulated crimping: Red, Blue, Yellow
- Dimensions (mm): 255(L)

Crimping Range (mm ²)	
0.5	■
1.25 - 2	■
2.5	■
3	■
5	■
5.5	■



HYAC5 - Crimper: Bootlace Ferrules (DIY)



- Insulated, single and twin entry ferrules
- Uninsulated ferrules
- Adjustable crimping pressure
- Ratchet release
- Dimensions (mm): 203(L) x 78(W)

Crimping Range (mm ²)	
0.5 - 0.75	■ ■
1 - 1.5	■ ■
2.5	■
4	■
6	■



HYTB4 - Compact Crimper: Bootlace Ferrules



- Insulated, single and twin entry ferrules
- Uninsulated ferrules
- Adjustable crimping pressure
- Ratchet release
- Dimensions (mm): 190(L) x 70(W)

Crimping Range (mm ²)	
0.25	■
0.5	□
0.75	■
1.5	■
2.5	■
4	■
6	■



HYAC6 - Crimper: Bootlace Ferrules



- Insulated, single and twin entry ferrules
- Uninsulated ferrules
- Adjustable crimping pressure
- Ratchet release
- Dimensions (mm): 203(L) x 76(W)

Crimping Range (mm ²)	
6	■
10	■
16	■



HYAC8 - Crimper: Bootlace Ferrules (DIY)



- Insulated, single and twin entry ferrules
- Uninsulated ferrules
- Push to release lever
- 4 Point pressure adjustment screw
- Strong, lightweight glass fibre reinforced nylon handles
- Square (quad) profile
- Dimensions (mm): 175(L) x 80(W)

Crimping Range (mm ²)	
0.08 - 6	



HYAC9 - Crimper: Bootlace Ferrules



- Insulated, single and twin entry ferrules
- Uninsulated ferrules
- Push to release lever
- 6 Point pressure adjustment screw
- Strong, lightweight glass fibre reinforced nylon handles
- Hexagonal profile
- Dimensions (mm): 170(L) x 80(W)

Crimping Range (mm ²)	
0.08 - 6	



HYAC17 - Crimper: Bootlace Ferrules



- Insulated, single and twin entry ferrules
- Uninsulated ferrules
- Adjustable crimping pressure
- Ratchet release
- Dimensions (mm): 229(L) x 60(W)

Crimping Range (mm ²)	
25	■
35	■



HYTB6 - Compact Crimper: Bootlace Ferrules



- Insulated, single and twin entry ferrules
- Uninsulated ferrules
- Adjustable crimping pressure
- Ratchet release
- Dimensions (mm): 190(L) x 70(W)

Crimping Range (mm ²)	
6	■
10	■
16	■



HYAC3 - Crimper: Coax



- Adjustable crimping pressure
- Ratchet release
- Dimensions (mm): 241(L) x 70(W)

Crimping Range (mm ²)
1.72
2.5
5.4
6.48
8.2



HYTT11 - Crimper: Tab Terminals



- Griptite
- Roll over crimp
- Adjustable crimping pressure
- Ratchet release
- Dimensions (mm): 229(L) x 70(W)

Crimping Range (mm ²)
0.5 - 1
1.1 - 2.5
4 - 6



ASA486 - Crimper: Modular Connectors



- Cutting and stripping for 4, 6 and 8 conductors
- Dimensions (mm): 228(L)
- Weight: 360g

For crimping handset all in one
4P4C
4P4C plugs
6P6C (RJ-12)
6P4C (RJ-11)
8P8C (RJ-45)



RJ86 - Crimper: Modular Connectors

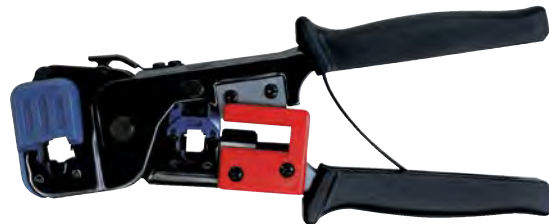

- Cutting and stripping for modular plugs
- Dimensions (mm): 220(L)
- Weight: 320g

Connectors
RJ11
RJ12
RJ45



HYTB2 - Compact Crimper: Uninsulated Terminals



- Ratchet release
- Adjustable crimping pressure
- Dimensions (mm): 190(L) x 70(W)

Crimping Range (mm ²)
YYTB2
0.25
1.5
2.5



HYTT8/ HYTT9 - Crimper: Uninsulated Terminals



HYTT9

- Ratchet release
- Dimensions (mm): 266(L) x 66(W)

Crimping Range (mm ²)	
HYTT8	HYTT8
1.5	10
2.5 - 4	16
6 - 8	
10	



CCMP - Multi-Crimp (DIY)



- Long handles - solid leverage
- Cutting and indent crimping
- Dimensions (mm): 250(L)

Crimping Range (mm ²)
0.5 - 10



T16 - Crimper: Uninsulated Terminals



- Ratchet release
- Dimensions (mm): 325(L)

Crimping Range (mm ²)
1.5
2.5
4 - 6
10
16



PVCT46 - Crimper: PV (Solar)



- Standard die for 2.5/4/6mm² (AWG14/12/10) solar PV cable
- Adjustable crimping pressure
- MC4 Solar connectors
- Right angle head design- Prevents wrist bending
- Pull force on crimping pins - 45kg

Crimping Range (mm ²)	
Metric	AWG
2.5	10
4	12
6	14



Spare Accessory

Code	Description
PVCT46DIE	Replacement die



PVCT46B - Crimper: PV (Solar)



- Standard die for 2.5/4/6mm² (AWG14/12/10) solar PV cable
- Suitable for Bizlink connectors

Crimping Range (mm ²)	
Metric	AWG
2.5	10
4	12
6	14



HT16UT - Indent Crimper (DIY)



- Uninsulated terminals and cable lugs
- Ratchet release
- Dimensions (mm): 270(L)
- Weight: 470g

Crimping Range (mm ²)	
Uninsulated Terminals	Cable Lugs
1.25	1.5
1.5	2
2	6
6	10
10	16



HD16L - Indent Crimper



- Uninsulated terminals and cable lugs
- Ratchet release
- Dimensions (mm): 270(L)
- Weight: 520g

Crimping Range (mm ²)	
Uninsulated Terminals	Cable Lugs
1.25	1.5
1.5	2
2	6
6	10
10	16



HD22L - Indent Crimper



- Uninsulated terminals and cable lugs
- Ratchet release
- Dimensions (mm): 360(L)
- Weight: 780g

Crimping Range (mm ²)	
Uninsulated Terminals	Cable Lugs
5.5	6
6	10
10	16
16	22
22	25



HT25UT - Indent Crimper (DIY)



- Uninsulated terminals and cable lugs
- Ratchet release
- Dimensions (mm): 350(L)
- Weight: 700g

Crimping Range (mm ²)	
Uninsulated Terminals	Cable Lugs
5.5	6
6	10
10	16
16	22
22	25



HD25X - Hex Crimper



- Cable lugs
- Ratchet release
- Dimensions (mm): 354(L)
- Weight: 780g

Crimping Range (mm ²)	
6	
10	
16	
25	



AK15 - Indent Crimper (Lobster)



- Ratchet release
- Control cycle mechanism
- Dimensions (mm): 270(L)

Crimping Range (mm ²)
1.25
2
5.5
8



AK19 - Indent Crimper (Lobster)



- Ratchet release
- Control cycle mechanism
- Dimensions (mm): 290(L)

Crimping Range (mm ²)
2
5.5
8
16



HT0650 - Hex Crimper (DIY)



- Hexagonal crimper with replaceable rotating dies
- Tubular cable lugs and connectors
- Dies included
- Dimensions (mm): 380(L)
- Weight: 1.5kg

Crimping Range (mm ²)
6,10, 16, 25, 35, 50

Replacement Die Code
HD650HTDIE



HT06120 - Hex Crimper (DIY)



- Hexagonal crimper with replaceable rotating dies
- Tubular cable lugs and connectors
- Dies included
- Dimensions (mm): 650(L)
- Weight: 3.8kg

Crimping Range (mm ²)
6, 10, 16, 25, 35, 50, 70, 95, 120

Replacement Die Code
HD6120HTDIE



HD0650AU - Hex Crimper



- Hexagonal crimper with replaceable rotating dies
- Tubular cable lugs and connectors
- Dies included
- Dimensions (mm): 390(L)
- Weight: 1.1kg

Crimping Range (mm ²)
6, 10, 16, 25, 35, 50

Replacement Die Code
HD650HTDIE



HD06120AU - Hex Crimper



- Hexagonal crimper with replaceable rotating dies
- Tubular cable lugs and connectors
- Dies included
- Dimensions (mm): 650(L)
- Weight: 4kg

Crimping Range (mm ²)
6,10, 16, 25, 35, 50, 70, 95, 120

Replacement Die Code
HD6120HTDIE



HD25150AU - Hex Crimper



- Hexagonal crimper with replaceable rotating dies
- Tubular cable lugs and connectors
- Dies included
- Dimensions (mm): 650(L)
- Weight: 4kg

Crimping Range (mm ²)
25, 35, 50, 70, 95, 120, 150

Replacement Die Code
HD25150DIE



K05L (K05B) - Hex Crimper (Klauke)



- Hexagonal crimper with replaceable rotating dies
- Tubular cable lugs and connectors
- Dies included
- Dimensions (mm): 390(L)

Crimping Range (mm ²)
6, 10, 16, 25, 35, 50



K06L (K06B) - Hex Crimper (Klauke)



- Hexagonal crimper with replaceable rotating dies
- Tubular cable lugs and connectors
- Dies included
- Dimensions (mm): 390(L)

Crimping Range (mm ²)
6, 10, 16, 25, 35, 50, 70, 95, 120



BOWCRIMPT - Indent Crimper



- Screw adjustable crimp range
- Forged steel
- Up to 95mm (Aluminium) lugs
- Dimensions (mm): 570(L)
- Weight: 3.1kg

Crimping Range (mm ²)
6, 10, 16, 25, 35, 50, 70, 95, 120



The Importance of a High-Quality Crimp

When a crimping tool is used on a terminal, two crimps need to take place. One is the electrical connection between the conductor and terminal. The other is the insulation crimp which provides strain relief against vibration and tension.

It is important that the electrical connection is gas-tight without any voids between the wire strands and the terminal. If there are any voids present, then corrosion can occur causing resistance and excessive heat which damages the electrical connection.

Selecting the correct crimping tool ensure a tight crimp preventing future deterioration of the electrical connection and insulation breakage.

Assembly Instructions for Cable Lugs and Ferrules

- Strip conductor according to insertion depth of lug barrel
- Conductor ends must be cleaned before termination
- Insert conductor fully into cable lug or ferrule
- Observing the crimping sequence (see pic right), crimp the cable lug or ferrule using the appropriate crimping tool

How to maintain the Crimping Tools

- Lubricate axles and other movable parts regularly
- Lubrication* is recommended at least every 10,000 cycles or when tool is exposed to dirt or other contaminants

*Use a light mineral-free oil



Using a crimper die designed for a terminal with a larger barrel, results in a lower crimp reduction which could cause overheating due to poor electrical contact.

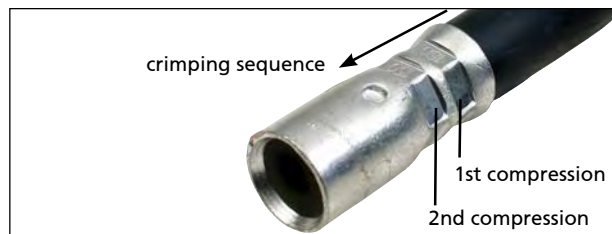
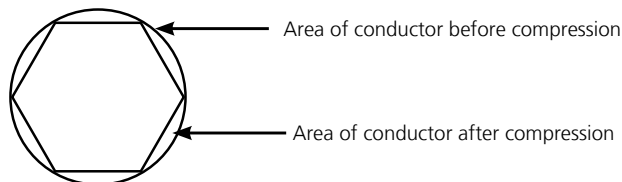

HYCP185 - Hand Hydraulic Crimper

- Dies excluded

HYCP185KT - Hand Hydraulic Crimper Kit

- Dies included



- Built-in bypass relief valve for constant compression
- Head rotates 180°
- Force at die face: 5.2 metric ton
- Accepts BEKU type dies
- Dies sold separately
- Dimensions (mm): 373(L) x 140(W)
- Weight: 2.14kg

Die Code	Crimp Sizes (mm ²)
H1851016D	10 and 16 (dual die)
H1852535D	25 and 35 (dual die)
H1855070D	50 and 70 (dual die)
H1859512D	95 and 120 (dual die)
H185150D	150 (single die)
H185185D	185 (single die)



Crimping Range (mm ²)
10, 16, 25, 35, 50, 70, 95, 120, 150, 185

HYCP240 - Hand Hydraulic Crimper

- Dies excluded

HYCP240KT - Hand Hydraulic Crimper Kit

- Dies included



- Built-in bypass relief valve for constant compression
- Head rotates 180°
- Force at die face: 5.2 metric ton
- Accepts BEKU type dies
- Dies sold separately
- Dimensions (mm): 377(L) x 142(W)
- Weight: 2.4kg

Die Code	Crimp Sizes (mm ²)
H1851016D	10 and 16 (dual die)
H1852535D	25 and 35 (dual die)
H1855070D	50 and 70 (dual die)
H1859512D	95 and 120 (dual die)
H185150D	150 (single die)
H185185D	185 (single die)
H240240D	240 (single die)



Crimping Range (mm ²)
10, 16, 25, 35, 50, 70, 95, 120, 150, 185, 240

HYCP400 - Hand Hydraulic Crimper

- Excludes dies

HYCP400KT - Hand Hydraulic Crimper Kit

- Includes dies



- Automatic low/high - pressure conversion with rapid/slow operating motion
- Pressure relief valve for overload protection
- Head rotates 180°
- Force at die face: 12 ton (700 bar)
- C-head opening: 32mm
- Dies sold separately
- Dimensions (mm): 612(L) x 174(W)
- Weight: 6.5kg

Die Code	Die No.	A	B	C
CP40016D	Cu-16	7.20	3.12	14
CP40025D	Cu-25	8.43	3.67	14
CP40035D	Cu-35	10	4.33	16
CP40050D	Cu-50	11.60	5.02	16
CP40070D	Cu-70	13.70	5.95	15.60
CP40095D	Cu-95	15.90	6.85	15.70
CP400120D	Cu-120	17.98	7.79	16
CP400150D	Cu-150	20.10	8.70	15
CP400185D	Cu-185	22.33	9.67	14
CP400240D	Cu-240	25.43	11.01	13
CP400300D	Cu-300	28.44	12.32	11.20
CP400400D	Cu-400	30	14.55	11.50

Crimping Range (mm ²)
10, 16, 25, 35, 50, 70, 95, 120, 150, 185, 240, 300, 400



Use one die size larger for crimping Aluminium lugs



K240KT - Battery Powered Hydraulic Crimper Kit

- Approximately 200 crimps per charge at 50mm²
- 18 Volt Lithium-Ion battery powered (2 included)
- 5.3 Ton die force
- Head rotates 180°
- *Dies included
- Dimensions (mm): 354(L) x 91(W) x 73(H)
- Weight: 2.67kg

Die Code*	Crimp Sizes (mm ²)
H1851016D	10 and 16 (dual die)
H1852535D	25 and 35 (dual die)
H1855070D	50 and 70 (dual die)
H1859512D	95 and 120 (dual die)
H185150D	150 (single die)
H185185D	185 (single die)
H240240D	240 (single die)

Spare Accessories

Code	Description
HYLECBATT	Battery 18V 5Ah



HYLEC32 - Battery Powered Crimper

- Approximately 60 crimps per charge at 50mm²
- 12.7 ton die force
- Head rotates 180°
- 18 Volt Lithium-Ion battery powered
- C-head opening: 32mm
- Dies sold separately
(Refer to **HYCP400KT** See p117)
- Dimensions (mm): 300(L) x 89(W) x 353(H)
- Weight: 6kg (without battery)

Crimping Range (mm ²)
10, 16, 25, 35, 50, 70, 95, 120, 150, 185, 240, 300, 400

Spare Accessories

Code	Description
HYLECBATT	Battery 18V 5Ah (14V battery available on request)



HYUC6 - Hand Hydraulic Indent Crimper



- Only for round aluminium lugs and ferrules for overhead lines
- 7 Ton die force
- Head rotates 360°
- Permanent internal dies
- C-head opening: 36mm
- Two-stage hydraulic system
- Dimensions (mm): 563(L) x 180(W)
- Weight: 6kg

Crimping Range (mm ²)
25, 35, 50, 70, 95, 120



HYPNST - Hydraulic Punch Drive Kit with Pump



- Punch electrical panels and switchboards
- Punch driver max output: 12.7 tons
- 2 Draw studs with draw stud adaptor
- Hand pump output: 590 bar
- Weight: 7.6kg

Punch Capacity
3.2mm mild steel
1.6mm stainless steel



Code	Punch Sizes (mm)	Draw Stud
HYPH5216D	16	R1STUD
HYPH5220D	20	
HYPH5225D	25	
HYPH5232D	32	RSSTUD
HYPH5240D	40	
HYPH5250D	50	
R1STUD	3/8" (16.20, 25 Dies)	3/8-24unf thread pitch
RSSTUD	3/4" (32.40, 50 Dies)	3/4-16unf thread pitch



HYTP - Rotary Punch Kit

- Used to punch electrical panels and switchboards
- Punch force: 60kN
- 2 Draw studs
- Weight: 6.5kg

Punch Capacity
3mm mild steel
1.6mm stainless steel (HYLARGESTUD only)



Code	Punch Sizes (mm)	Draw Stud
HY20DIE	20	 HYSMALLSTUD
HY22DIE	22	
HY25DIE	25	
HY32DIE	32	 HYLARGESTUD
HY40DIE	40	
HY50DIE	50	
HYSMALLSTUD	7/16" (20,22,25 Dies)	3/8-24unf thread pitch
HYLARGESTUD	3/16" (32,40,50 Dies)	3/4-16unf thread pitch



HY360RP - 360° Rotational Punch Kit

- Used to punch electrical panels and switchboards
- Head can be rotated 360° through rotating axis
- 2 Draw studs
- Weight: 6.5kg

Punch Capacity
3.5mm mild steel
1.6mm stainless steel (HYLARGESTUD only)

Code	Punch Sizes (mm)	Draw Stud
HY20DIE	20	 HYSMALLSTUD
HY22DIE	22	
HY25DIE	25	
HY32DIE	32	 HYLARGESTUD
HY40DIE	40	
HY50DIE	50	
HYSMALLSTUD	7/16" (20,22,25 Dies)	3/8-24unf thread pitch
HYLARGESTUD	3/4" (32,40,50 Dies)	3/4-16unf thread pitch

FH700FP - Hydraulic Foot Pump



- Two-stage pumping action (700 bar)
- Includes 2 metre hose
- Pioneer 3000 standard coupling
- Dimensions (mm): 720(L)
- Weight: 12kg



HH700HP - Hydraulic Hand Pump



- Two-stage pumping action (700 bar)
- Includes 2 metre hose
- Automatic pressure release
- Pioneer 3000 standard coupling
- Dimensions (mm): 590(L)
- Weight: 10kg



EP30MS - Electric Hydraulic Pump

- Two stage high performance
- Max pressure: 700 bar
- 2 way, 2 position manual valve
- Drive unit: 220V/AC or 110V/AC 50/60Hz
- Includes 5 meter remote control cable
- Dimensions (mm): 454(H)
- Weight: 15kg (without oil)

HYCP400HE - Hydraulic Crimp Head*



- Max output: 14.01 tons
- Dies sold separately (Refer to **HYCP400KT** table on p110 for die part numbers)
- Pioneer 3000 standard coupling
- Jaw opening: 32mm
- Oil required: 55cc
- Length: 261mm
- Weight: 4.2kg

Crimping Range (mm²)
16 - 400



HYCP630HE - Hydraulic Crimp Head*



700 bar



Single action cylinder with spring return

- Max output: 24.9 tons
- Pioneer 3000 standard coupling
- Includes hard carry case
- Oil required: 89cc
- Length: 320mm
- Weight: 5.6kg



Crimping Range (mm²) includes dies
400, 500, 630

ADP630HE Die Adaptor



Adapter designed for HYCP630HE to interchange with die sets from other 12-ton tools (up to 400mm²) see dies on p110

Die Code	Crimp Sizes (mm ²)
CP630400D	400
CP630500D	500
CP630630D	630

*All heads require a hydraulic pump

HYCC85 - Hydraulic Cable Cutter

- Two stage pumping action for rapid blade advance
- Lock pin type cutting head
- Head rotates 180°
- Output: 4.9 tons
- Cuts: Copper strands - 28mm
Aluminium strands - 38mm
Telephone cable CCP - 85mm
Underground cable - 50mm[#]
- Dimensions (mm): 715(L)
- Weight: 10kg



Copper Cable

HYCC85HE - Hydraulic Cutting Head*

- Operates off any pump (Max pressure 700 bar)
- Lock pin type cutting head
- Blade easily replaceable
- Output: 4.9 tons
- Cuts: Copper strands - 28mm
Aluminium strands - 38mm
Telephone cable CCP - 85mm
- Pioneer 3000 standard coupling
- Dimensions (mm): 460(L)
- Weight: 7.2kg



Copper Cable

HYCC075S - Hydraulic Cutting Head*

- Cuts: 4-Core Underground cable - approx 65mm
*Copper strands - 75mm
*Aluminium strands - 75mm
* XLPE up to 60mm
- Fast cutting with remote operation
- Operated any hydraulic pump with pressure of 700 bar
- Output: 20 tons
- Dimensions (mm): 373(L)
- Weight: 8.7kg



Armoured Cable



Aluminium Cable

HYCC096 - Hydraulic Armoured Cable Cutter Head*

- Two stage pumping action for rapid blade advance
- Output: 13.5 tons
- Max pressure: 700 bar
- Cuts: Copper strands - up to 95mm diameter
Aluminium strands - up to 95mm diameter
Armoured cable - up to 70mm diameter
- Not for XLPE cable
- Spare blades available on request (**HY096BLD**)
- Pioneer 3000 standard coupling
- Dimensions (mm): 412(L) x 247(W) x 105(H)
- Weight: 8.1kg



Armoured Cable

HYCC065HE- Hydraulic Cutting Head*

- Fast cutting with remote operation
- Max pressure: 700 bar
- Max output: 7.5 tons / 73.5kN
- Cutting capacity: Copper cable - 60mm
- Aluminium cable - 60mm
- CCP cable - 65mm
- Underground cable - 65mm (except armoured cable)
- Not for piano wire
- Dimensions (mm): 419(L)
- Weight: 4.9kg

CC22 / CC38 - Cable Cutter



CC22

	CC22	CC38
Cuts copper and aluminium cable (mm ²)	Up to 25	Up to 38
Cable diameter (mm)	Up to 9.2	Up to 11.4
Overall length (mm)	165	



Copper Cable



Aluminium Cable

CC60 - Cable Cutter



	CC60
Cuts copper and aluminium cable (mm ²)	Up to 60
Cable diameter (mm)	Up to 13.6
Overall length (mm)	235



Copper Cable



Aluminium Cable

CC100 - Cable Cutter

- Not for cutting steel wire or steel



	CC100
Cuts copper and aluminium cable (mm ²)	120
Overall length (mm)	320
Weight (g)	700



Copper Cable



Aluminium Cable

CC250 / CC500 - Cable Cutter



CC250

	CC250	CC500
Cuts copper and aluminium cable (mm ²)	250	500
Overall length (mm)	730	800
Weight (kg)	1.54	2.93

Spare Accessories

Code	Description
CC500BLD	Spare Blades



Copper Cable



Aluminium Cable

SCC60 - Steel Cable Cutter

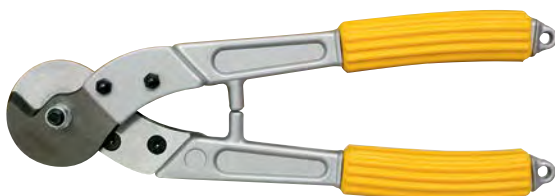

	SCC60
Cuts copper cable (mm ²)	60
Cuts wire rope (mm)	7 Max
Cuts steel rod (mm)	5 Max
AWG (1/0) Max	0
Overall length (mm)	310
Weight (g)	730



Copper Cable



Wire Rope

SCC200 - Steel Cable Cutter



	SCC60
Cuts copper cable (mm ²)	150
Cuts wire rope (mm)	12 Max
Cuts steel rod (mm)	9 Max
AWG MCM Max	300
Overall length (mm)	600
Weight (kg)	1.8

Spare Accessories

Code	Description
CC200BLD	Spare Blade



Copper Cable



Wire Rope

HTJ40 - Ratchet Cable Cutter



- ACSR and armoured Cu / Al cable, steel chain, stainless steel pipe & tube, and tree branches
- Max diameter 38mm



Copper Cable



Aluminium Cable



Armoured Cable

RCC500 - Core Cutter



- Capacity: 50mm diameter
- Not for steel or hard copper
- Spare blades available
- Copper (30mm²), aluminium (600mm²) and multi conductor cable cutter
- One hand single speed ratchet mechanism
- Lockable in closed position



Copper Cable



Aluminium Cable

HTJ55 - Ratchet Cable Cutter



- Cutting, XLPE, armoured Cu / Al cable
- Max 55mm



Copper Cable



Aluminium Cable



Armoured Cable

HTJ76 - Ratchet Cable Cutter



- Capacity: 70mm diameter
- Short and extendable telescopic handles
- 53-55 HRC blade hardness
- SWA cable with multi cores, total cross section size not exceed 4x 120mm² (4x40 AWG)
- Copper and armoured cable cutter
- Dimensions (mm): 420(L) x 205(W)
- Weight: 3.7kg



Copper Cable



Armoured Cable



Marine Cable

RCC325PH - Ratchet Cable Cutter



- Capacity: 380mm²
- Not for use on ACSR cable or steel wire
- Diameter: 32.5mm
- Single speed ratchet mechanism
- Copper and aluminium cable cutter
- Dimensions (mm): 290(L)
- Weight: 990g



Copper Cable



Aluminium Cable

HTJ35 - Ratchet Cable Cutter



- Capacity: 32mm diameter
- Not for steel or hard copper
- Dimensions (mm): 252(L) x 84(W)
- Weight: 690g



Copper Cable

Electrician's Pliers (DIY)



LCP180

- High grade carbon steel
- Cutting edge for soft wire

Code	Length (mm)	
	Overall	Head
LCP150	160	38
LCP180	180	45
LCP200	200	45

Long Nose Pliers (DIY)



LLN200

- High grade carbon steel
- Cutting edge for soft wire

Code	Length (mm)	
	Overall	Head
LLN200	200	45

Diagonal Cutters (DIY)



LDC180

- High grade carbon steel
- Cutting edge for soft wire

Code	Length (mm)	
	Overall	Head
LDC125	110	25
LDC150	160	30
LDC180	180	35
LDC200	200	30

Groove Joint Pliers (DIY)



LGJ250

- High grade carbon steel

Code	Length (mm)	
	Overall	
LGJ250	250	
LGJ300	300	

SP115N - Cable Cutter (DIY)



- Stainless steel
- Cuts up to 1.2mm copper



Copper Cable

8325 - Groove Joint Pliers



- 5 Positions
- Individual high frequency induction hardened
- Length: 250mm

Electrician's Pliers



SEP180

- Chrome plated satin finish
- High grade carbon steel
- Cutting Edge for soft wire
- PVC insulated handles



Code	Length (mm)	
	Overall	Head
SEP160	160	60
SEP180	180	65
SEP200	200	70

Long Nose Pliers



SLN200

- Chrome plated satin finish
- High grade carbon steel
- Cutting edge for soft wire
- PVC insulated handles



Code	Length (mm)	
	Overall	Head
SLN160	160	75
SLN200	200	100

Diagonal Cutters



SDC180

- Chrome plated satin finish
- High grade carbon steel
- Cutting edge for soft wire
- PVC insulated handles



Code	Length (mm)	
	Overall	Head
SDC160	160	40
SDC180	180	50
SDC200	200	60

Electrician's Wire Stripper

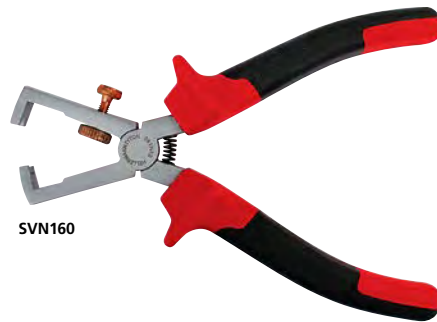

SVN160

- Chrome plated satin finish
- High grade carbon steel
- Adjustable stripping size
- PVC insulated handles



Code	Length (mm)	
	Overall	Head
SVN160	160	60

HTS250 - Aviation Tin Snips

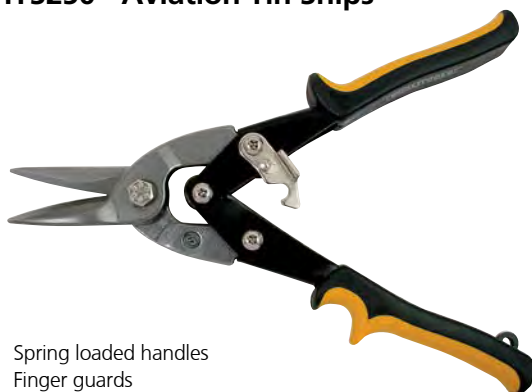

- Spring loaded handles
- Finger guards
- Drop forged chrome vanadium steel blades
- 250mm straight



Electrician's Pliers 1000V



HCP200H

- 1000V – IEC60900 SABS approved
- Chrome molybdenum steel/hardness 38 - 44 HRC
- Cutting edges – induction hardness 58-62 HRC
- General uses – mild steel wire
- **HCP200H** (Piano wire) tempered high-carbon steel



Code	Cutting Capacity (mm)			Length(mm)	
				Overall	Head
HCP180	<input type="checkbox"/> 2.8	<input checked="" type="checkbox"/> 2.5		180	62
HCP200	<input type="checkbox"/> 3.0	<input checked="" type="checkbox"/> 2.5		200	67
HCP200H	<input type="checkbox"/> 3.8	<input checked="" type="checkbox"/> 2.7	<input checked="" type="checkbox"/> 2.2	200	65

Long Nose Pliers 1000V



HLN200

- 1000V – IEC60900 SABS approved
- Chrome molybdenum steel/hardness 38 - 44 HRC
- Cutting edges – induction hardness 58-62 HRC
- General uses – mild steel wire



Code	Cutting Capacity (mm)		Length(mm)	
			Overall	Head
HLN160	<input type="checkbox"/> 2.5	<input checked="" type="checkbox"/> 1.6	160	68
HLN200	<input type="checkbox"/> 2.5	<input checked="" type="checkbox"/> 1.8	200	93

Diagonal Cutters 1000V Heavy Duty



HDC205H

- 1000V – IEC60900 SABS approved
- Chrome molybdenum steel/hardness 38 - 44 HRC
- Cutting edges – induction hardness 58-62 HRC
- General uses – mild steel wire
- **HDC205H** Piano wire



Code	Cutting Capacity (mm)			Length(mm)	
				Overall	Head
HDC160	<input type="checkbox"/> 2.8	<input checked="" type="checkbox"/> 2.0		160	48
HDC180	<input type="checkbox"/> 3.0	<input checked="" type="checkbox"/> 2.5		180	44
HDC205H	<input type="checkbox"/> 3.2	<input checked="" type="checkbox"/> 3.2	<input checked="" type="checkbox"/> 2.5	205	54

Combination Plier and Crimper 1000V



PC230W

- High grade carbon steel
- Indent crimper
- Cutting edge for soft and hard wire



Code	Cutting Capacity (mm)	Length(mm)	
		Overall	Head
PC230W	<input type="checkbox"/> 3.0	225	80

VDE 1000V Range Test

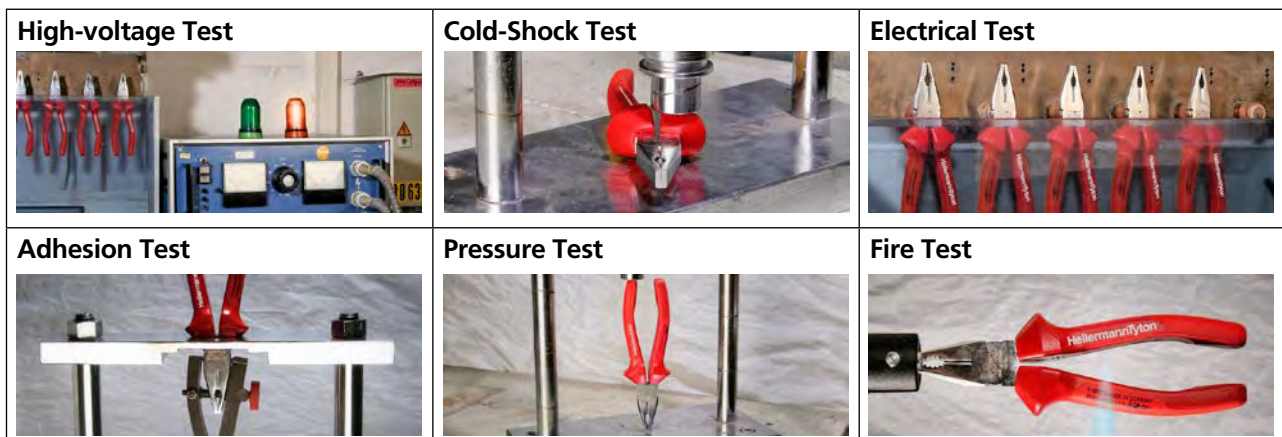

Cutting Capacity

- Medium hard wire, wire nails Hard wire, steel wire Piano wire, heat treated steel wire

45092 - Stripmaster



- Strips wire clean and eliminates all nicking, cutting or fraying
- Light gauge wire and cable: automotive, aviation, telephone, fixture, radio and instrument

Code	Wire (mm ²)	No. of Holes	Replacement Blades (Pair) Code
45092	0.75 - 6	6	L4421M

PVST46 - PV Stripping Tool



- Standard die for 2.5, 4, 6mm² (AWG14, 12, 10) solar PVC cable
- Insulation stripping distance guide
- Automatic spring release action
- Non-slip grip



Parameter	Metric	AWG
Die range	25, 4, 6	14, 12, 10

Wire Stripper

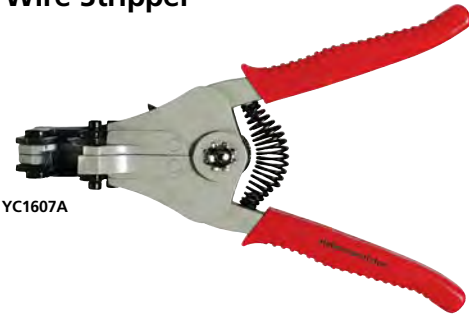

YC1607A

- General purpose wire stripper

Code	Wire Sizes (mm ²)
YC1607A	0.5 - 2
YC1607B	1 - 3.2

T-Type® - Wire Stripper and Cutter



45120

- Quick, easy, clean stripping and cutting of small solid and flexible wires in electronic instruments and appliances

Code	AWG Solid	AWG Stranded
45120	10-18	12-20
45121	14-24	16 - 26

PTS4 - Wire Stripper and Cutter



- Automatic adjustment
- Self-adjusting cutting-stripping tool with pressure adjustment of blade incision
- Strip multiple electric cables



Code	Wire Sizes (mm ²)
PTS4	0.2 - 6

RCS0425 - Rotary Stripper



- Blade angle adjustable
- Lateral or vertical stripping
- PVC, Teflon and THHN insulations

Code	Wire Φ (mm ²)	Length (mm)	Weight (g)
RCS0425	4 - 25	186	150

MTOOL - 15-in-1 Multi Tool

- Stainless steel
- Includes belt pouch
- Needle nose pliers
- Screwdriver (small, medium, large)
- Regular pliers
- Scissors
- Saw
- Can, bottle opener
- Sharp knife
- Fish scaler/hook remover
- Phillips screwdriver
- Single file
- Double file (other side)



PTOOL9 - 9-in-1 Pocket Tool



- 420 Stainless steel
- Weight: 49g

WAK1 - Retractable Utility Knife and Stripper



- Cutter length: 150mm
- Die-cast zinc body
- Retractable spring loaded
- Heavy duty 60mm blade included
- Easy slide carriage to retract blade
- Fold over safety feature
- Secure rubber grip

Spare Accessories

Code	Description
BHD5	5 Piece Heavy Duty Blades

WAK2 - Manual Retractable Utility Knife



- Cutter length: 150mm
- Die-cast zinc body
- Retractable spring loaded
- Heavy duty 60mm blade included
- Easy slide carriage to retract blade
- Ergonomic
- Secure rubber grip

Spare Accessories

Code	Description
BHD5	5 Piece Heavy Duty Blades

WAKTOOL - 6-in-1 Utility Knife



- Blade: SK5 (BHD5)
- Handle: Aluminium
 - TORX T6 and T8
 - TORX T10 and T15
 - Flat screwdriver
 - Phillips screwdriver
- Weight: 66g

S25 - PVC Pipe Cutter



- Pipe diameter 34mm
- Metal handle



PVC Pipe

WAK3 - Snap-off Knife Blades



- Supplied in plastic holder
- 10 Piece

Code	Sizes	Length
WAK3BLD	18mm	100mm

BHD5 - 5 Piece Heavy Duty Blades

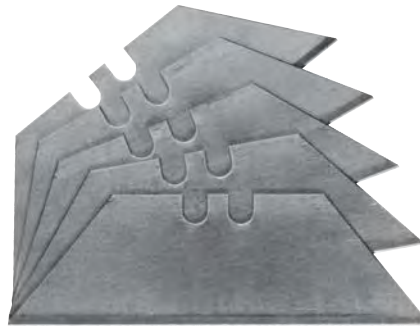

- Blade length: 60mm
- **WAK1, WAK2** and **WAKTOOL** (p122)

319 - Bahco Hacksaw



- Blade length: 300mm
- Die-cast aluminium frame
- 55° blade mounting
- Soft grip handle
- Lightweight



Blade Tension Adjuster

H015 - Junior Hacksaw (DIY)



- Blade length: 150mm
- Heavy duty

Spare Accessories

Code	Description
JUNHSBLD	Junior Hacksaw Blade

H100A - Heavy Duty Deluxe Hacksaw

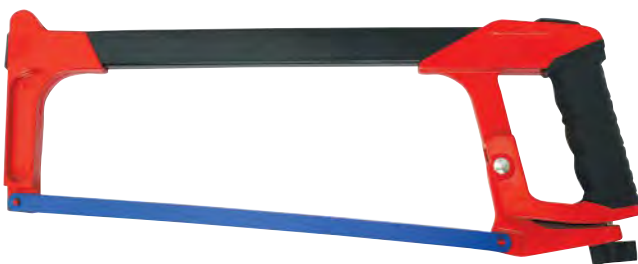

- Blade length: 300mm
- Heavy duty
- Spare blade storage in top handle

P100A - Heavy Duty Deluxe Hacksaw



- Blade length: 300mm
- Heavy duty
- Overmould frame

Hacksaw Blades

- 10 Blades per pack

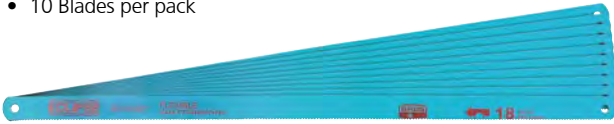

HSBLD18HS - Eclipse

- Low alloy



HSBLD18U - Bahco



JUNHSBLD - Junior

Code	Description	Cut Type	Hacksaw Blades	
			Length (mm)	TPI
HSBLD18HS	High Speed Eclipse	Rough	300	18
HSBLD24HS		General		24
HSBLD32HS		Precision		32
HSBLD18U	Bahco	Rough	300	18
HSBLD24U		General		24
HSBLD32U		Precision		32
JUNHSBLD	Junior	Precision	150	32

Chassis Punches

- Heavy duty
- Black anti-corrosive finish
- Can be used with various materials
- Accurate and burr free holes
- Capacity: Mild steel up to 3.5mm (10 gauge)



Application: fibreglass, aluminium, mild steel, plastic

Code	Diameter (mm)
CP20	20
CP22	22
CP25	25
CP32	32
CP40	40
CP50	50

Holesaws

- Heavy duty
- Complete with arbor
- Cutting depth: 12mm



Code	Diameter (mm)
HS18	18
HS20	20
HS21	21
HS25	25
HS32	32
HS40	40
HS50	50
HS63	63
HS75	75

TCT8KT - Tungsten Holesaw Kit: 8 Piece

- Ideal for mild steel, stainless steel, cast iron, fibre cement ceiling board, aluminium, wood and plastic



Code	Diameter (mm)
TCT16	16
TCT20	20
TCT22	22
TCT25	25
TCT32	32
TCTBITS	

Tungsten Holesaws

- Designed for drilling through aluminium, stainless steel, mild steel and fibre cement ceiling board
- Lasts up to 80% longer than standard holesaws
- Deep cutting depth
- Two cutting edges





Code	Diameter (mm)
TCT16	16
TCT20	20
TCT22	22
TCT25	25
TCT32	32
TCT40	40
TCT51	51
TCT64	64
TCT73	73
TCT76	76
TCT83	83

Bi-Metal Holesaws

- High speed bi-metal edge welded to an alloy steel back for heavy duty cutting
- Variable tooth pattern for "chatter-free" cutting - 4/6 TPI
- Maximum cutting depth 38mm
- Recommended for general timber and wood





Code	Diameter (mm)	Cutting Depth (mm)	Arbor Required
WHS16	16	30	WARB1 
WHS20	20	30	
WHS22	22	30	
WHS25	25	30	
WHS32	32	38	
WHS38	38	38	WARB2 
WHS40	40	38	
WHS51	51	38	
WHS60	60	38	
WHS64	64	38	
WHS70	70	38	
WHS73	73	38	
WHS76	76	38	
WHS83	83	38	
WHS95	95	38	
WHS105	105	38	
WHS111	111	38	

NB: Holesaws do not include arbors shown above.

WHS9KT - Bi-Metal Holesaw Kit: 9 Piece

- High speed bi-metal for heavy duty cutting
- Variable tooth pattern for “chatter-free” cutting - 4/6 TPI
- Holesaws sold individually
- Recommended for general timber and wood





Code	Diameter (mm)	Cutting Depth (mm)	Arbor Required
WHS20	20	30	WARB1 
WHS22	22	30	
WHS25	25	30	
WHS32	32	38	WARB2 or WADAP Adaptor 
WHS38	38	38	
WHS40	40	38	

WHS13KT - Bi-Metal Holesaw Kit: 13 Piece

- High speed bi-metal edge for heavy duty cutting
- Variable tooth pattern for “chatter-free” cutting - 4/6 TPI
- Spare drill bit included
- Holesaws sold individually
- Recommended for general timber and wood





Code	Diameter (mm)	Cutting Depth (mm)	Arbor Required
WHS20	20	30	WARB1 
WHS22	22	30	
WHS25	25	30	
WHS32	32	38	WARB2 or WADAP Adaptor 
WHS38	38	38	
WHS40	40	38	
WHS51	51	38	
WHS60	60	38	
WHS64	64	38	

WHS15KT - Bi-Metal Holesaw Kit: 15 Piece

- High speed bi-metal for heavy duty cutting
- Extension handle
- Variable tooth pattern for “chatter-free” cutting - 4/6 TPI
- Holesaws sold individually
- Recommended for general timber and wood



Code	Diameter (mm)	Cutting Depth (mm)	Arbor Required
WHS16	16	30	WARB1 
WHS19	19	30	
WHS20	20	30	
WHS22	22	30	
WHS25	25	30	WARB2 or WADAP Adaptor 
WHS32	32	38	
WHS40	40	38	
WHS51	51	38	
WHS60	60	38	
WHS64	64	38	
WHS76	76	38	



ENGSET - Un-insulated Screwdriver Set

- 6 Piece screwdriver set
- Flat blade and Phillips set
- Chrome vanadium
- TUV and GS spec

Length (mm)		Tip (mm)		Style
Overall	Head	Width	Thick	
150	75	3	0.5	-
180	100	4	0.8	
210	125	5	0.8	
250	150	7	1	
185	100	5	PH 1	+
222	125	6	PH 2	



95720 - Electronic Screwdriver Set

- 6 Piece screwdriver set
- Flat blade and Phillips set
- Chrome vanadium
- Screwdrivers are not sold separately
- Swivel top



Blade (mm)	Tip (mm)	Style
60	1.5	
75	2.5	
100	3	
125	2.5	
40	PH 00	+
60	PH 0	

HEXSET - Uninsulated Screwdriver Set

- 7 Piece including neon tester
- Flat blade and Phillips set
- Hexagon spanner grip for increased leverage
- Can be purchased individually



Code	Length (mm)		Tip (mm)		Style
	Overall	Head	Width	Thick	
HEX0945	175	90	4.5	0.6	-
HEX1060	195	100	5.5	0.8	
HEX1270	230	125	7	1	
HEX1580	255	150	8	1.2	
T45000 (Neon)	140	65	3	0.5	+
HEXP1	165	80	5	PH1	
HEXP2	195	100	6	PH2	

Can only be purchased individually (Not included in set)

HEX1790	295	175	10	1	-
---------	-----	-----	----	---	---



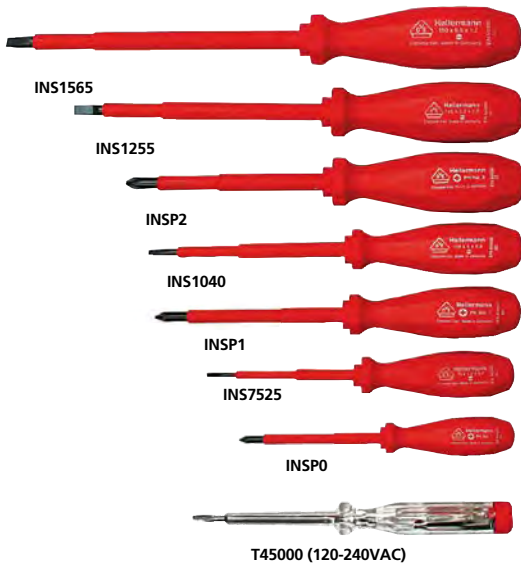

INSSET - Insulated Screwdriver Set 1000V AC / 1500V DC

- 8 Piece including neon tester
- Flat blade and Phillips set
- Can be purchased individually
- Voltage tester range 100 - 250V
- Chrome vanadium steel
- Hard storage case

Code	Length (mm)		Tip (mm)		Style
	Overall	Head	Width	Thick	
INS7525	166	75	3.5	0.4	-
INS1040	200	100	4	0.8	
INS1255	233	125	5.5	1	
INS1565	258	150	6.5	1.2	
T45000 (Neon)	140	60	3	0.5	+
INSP0	150	75	3	PH0	
INSP1	200	100	4.5	PH1	
INSP2	208	100	6	PH2	

Can only be purchased individually (Not included in set)

INS1780	290	175	8	1.2	-
INSPV1	170	85	2.5	PH1	+



ECOSET - Insulated Screwdriver Set 1000V (DIY)

- 7 Piece including neon tester
- Flat blade and Phillips set
- Insulated - 1000V
- Can be purchased individually
- Voltage tester range 100 - 250V

Code	Length (mm)		Tip (mm)		Style
	Overall	Head	Width	Thick	
ECO4100	210	100	4	0.8	-
ECO5125E	235	125	5.5	1	
ECO6150E	260	150	6.5	1.2	
T45000 (Neon)	140	60	3	0.5	+
ECOPV0	165	75	3	PH0	
ECOPV1	210	100	4	PH1	
ECOPV2	210	100	6	PH2	

Can only be purchased individually (Not included in set)

ECO375	150	75	3	0.5	-
--------	-----	----	---	-----	---



SWSET - Socket Wrench Set

- 7 Piece socket wrench set
- Chrome vanadium

Socket (mm)	Length (mm)		Style
	Overall	Head	
5	210	125	Hex
5.5	210	125	
6	210	125	
7	225	125	
8	225	125	
10	225	125	
13	240	125	

Can only be purchased individually

Code	Sizes (mm)	Head (mm)	Overall Length (mm)
SW8	8	225	330
SW10	10	225	330



VG250 - Vice Grips

- Chrome vanadium steel
- Cutting jaw
- Nickel plated

Code	Length (mm)	Weight (g)
VG250	250	600

Adjustable Spanner

- Chrome vanadium steel
- Corrosion resistant
- Graduated jaw

Code	Sizes (inches)	Length (mm)
AW150	6"	150
AW200	8"	200
AW300	12"	300

Combi Wrenches – BAHCO

- Reversible jaw for pipe use
- Jaw holds at maximum wrench opening
- Comfortable non-slip thermoplastic grip handles
- Complies to scientific ERGO™ process
- Standards: ISO 6787, DIN 3117, ASME B107.8M – 1996 and BS 6333

Code	Overall Length (mm)	Jaw Size (mm)	Jaw Thickness (mm)	Head Thickness (mm)	Weight (g)
9072P	257	33	8.7	15.2	430
9073P	308	35	11.9	17.6	745

O1003 - 10 Piece Allen Key Set



- Short arm
- Keyring
- Metric

Code	Sizes (mm)
O1003	1.5 - 2 - 2.5 - 3 - 4 - 5 - 5.5 - 6 - 8 - 10

O1604LM - 7 Piece Allen Key Set



- Long arm ball point
- Metric
- With plastic holder

Code	Sizes (mm)
O1604LM	2.5 - 3 - 4 - 5 - 6 - 8 - 10

O9FA - 9 Piece Allen Key Set



- Metric
- Foldable allen keys
- With plastic holder

Code	Sizes (mm)
O9FA	1.5 - 2 - 2.5 - 3 - 4 - 5 - 5.5 - 6 - 8

HUK1 - Universal Panel Key

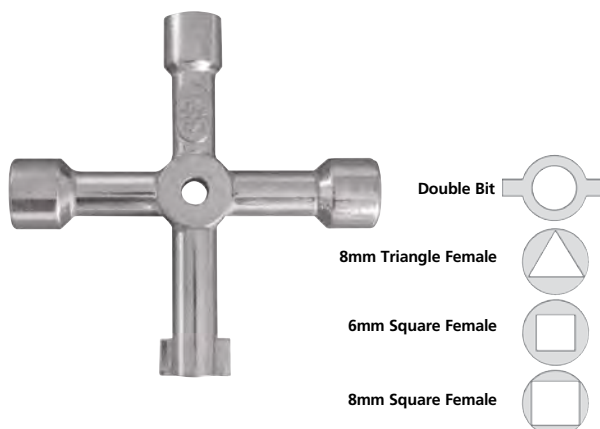

- Multi-purpose - electrical panels, gas, etc.
- Made from die cast zinc
- Ideal for maintenance work

Fish Tapes



FT60

H2230

Code	Length (m)
FT60	50 Steel Cable
H2230	30 Nylon

H5M - Tape Measures

- Tough ABS housing
- High quality scale
- Positive lock
- Integral clip

MHT5 - 5m Magnetic Tip Tape Measure

Magnetic Tip

- Tough ABS housing
- Positive lock
- Integral clip
- Magnetic tip
- Self-locking

HAMBP300 – Fibreglass Ball Pein Hammers 300g**TOOLBOX**

- 5 Tier toolbox
- Box dimensions (mm): 525(L) x 200(W) x 205(H)

HT762250 - Insulated Adjustable Spanner 1000V



HT762250

- Din 3117 B
- Burnished
- Opening width: 30mm
- EN/IEC 60900:2012

Code	Size (mm)	Weight (g)
HT762250	250	515

Insulated Extension Bars 1000V



HT285125



HT285250

- Chrome vanadium steel
- Locked system
- EN/IEC 60900:2012

Code	Sizes (inches)	Sizes (mm)	Weight (g)
HT285125	1/2"	125	190
HT285250	1/2"	250	400

Insulated Ring Spanners 1000V



HT21022

- DIN 7447
- Forged from chrome vanadium steel (DIN 838)
- Deep cranked
- EN/IEC 60900:2012



Code	Sizes (mm)	Weight (g)
HT21010	10	
HT21013	13	110
HT21014	14	160
HT21017	17	260
HT21019	19	290
HT21022	22	390

Insulated Open-Ended Spanners 1000V



HT20019

- DIN 7447
- Forged from chrome vanadium steel (DIN 838)
- Deep cranked



Code	Sizes (mm)	Weight (g)
HT20010	10	40
HT20013	13	65
HT20016	16	115
HT20017	17	115
HT20019	19	150

Insulated Screwdrivers 1000V



HT40055

- DIN 7437
- For slotted screws
- High quality PVC according to REACH-Regulation and PAK-Inspection



	Overall Length (mm)	Tip Thickness (mm)	Tip Width (mm)	Weight (g)
HT40055	125	1	5.5	10
HT40065	150	1.2	6.5	125
HT40016	200	1.6	10	

Insulated Cross Screwdrivers 1000V



HT4101

- DIN 7438
- For extremely high torque loads
- High quality PVC according to REACH-Regulation and PAK-Inspection



Code	Style	Weight (g)
HT4101	No 1	60
HT4102	No 2	95
HT4103	No 3	150

HT100205 - Insulated Pliers 1000V



HT100205

- Size: 205mm
- DIN ISO 5746
- Induction-hardened cutting edges
- Suitable for hard wire



Code	Size (mm)	Weight (g)
HT100205	205	390

HT104200 - Insulated Long Nose Pliers 1000V



HT104200

- Size: 200mm
- DIN ISO 5745
- Induction-hardened cutting edges
- Suitable for hard and soft wire



Code	Size (mm)	Weight (g)
HT104200	200	230

HT112180 - Insulated Diagonal Cutters 1000V



HT112180

- Size: 180mm
- DIN ISO 5749
- Swedish pattern
- Precision cutting edges relief-milled and induction-hardened



Code	Size (mm)	Weight (g)
HT112180	180	330

HT116240 - Insulated Water Pump Pliers 1000V



HT116240

- Size: 240mm
- Box joint
- Made from chrome vanadium 31 CrV3

Code	Size (mm)	Weight (g)
HT116240	240	350

HT280260 - Insulated Reversible Ratchet 1000V



- Chrome vanadium steel
- Locked system
- EN/IEC 60900:2012

Code	Length (mm)	Length (inches)	Weight (g)
HT280260	260	1/2"	700

Insulated 6-Point Sockets 1000V



- DIN 7448 with 1/2" square drive
- Made from chrome vanadium steel



Code	Sizes (mm)	Weight (g)
HT31613	13	75
HT31617	17	90

HT53040 - Insulated Hooked Cable Knife 1000V



- Strong blade for slitting and dismantling armoured cable



Code	Length (mm)	Weight (g)
HT53040	40	100

HT52545 - Insulated Cable Stripping Knife 1000V



- Blade with short, offset cutting edge



Code	Length (mm)	Weight (g)
HT52545	45	75

HT765250 - Insulated Mini Hacksaw 1000V



- Fully insulated

Code	Length (mm)	Weight (g)
HT765250	150	215

HT767450 - Insulated Hacksaw 1000V



- Fully insulated
- With plastic screw for tensioning the blade

Code	Length (mm)	Weight (g)
HT767450	450	300

HT125240 - Insulated Cable Cutter 1000V



- High-quality 2-colour multi-layered insulation
- For Aluminium and Copper wires
- Multi-wire up to 50mm²
- Dropped forged and oil hardened
- High quality PVC (REACH-Regulation and withstand the newest PAK-Inspection)
- EN 60900:2012 / IEC 60900:2012



Code	Length (mm)
HT125240	240



HT90026 - Insulated Tool Kit 1000V

- 26 Piece
- Dimensions (mm): 100(H) x 450(L) x 390(W)
- Weight: 4.4kg

Description	Sizes
Engineers Pliers	200mm
Side Cutters	160mm
Telephone Pliers	200mm
Reversible Ratchet	1/2"
Extension	250mm 1/2"
Stripper Knife	35mm blade
Cable Knife	40mm blade
Sockets	10, 11, 12, 13, 14, 17, 19mm
Open-Ended Spanner	10, 11, 12, 13, 14, 17, 19mm
Voltmeter	-
Screwdrivers	3.5 x 100, 5.5x125, 6.5x150, 8x175



HT91615 - Insulated Tool Kit 1000V

- 15 Piece
- Dimensions (mm): 100(H) x 450(L) x 390(W)
- Weight: 5kg

Description	Sizes
Reversible Ratchet	1/2"
Extension Bars	125 and 250mm 1/2"
T-Lever (HT290200)	1/2"
Ratchet Sockets	10, 12, 13, 14, 17, 19, 22mm
Allen Screw Sockets	5, 6, 8mm
Screwdriver	3.5 x 100mm

HT90029 - Insulated Tool Kit 1000V

- 29 Piece 1/2"
- Tool case: ABS shockproof
- Dimensions (mm): 80(H) x 415(L) x 320(W)



Description	Sizes (mm)
Reversible Ratchet Wrench	200
Extension Bar	125, 250
Hexagon Socket	4 x 120, 5 x 120, 6 x 120, 8 x 120
Socket	10, 11, 12, 13, 14, 16, 17, 18, 19, 22, 24, 27, 30, 32
Pliers	180
Nose Pliers	160
Diagonal Pliers	160
Adjustable Wrench	200
Slotted Screwdriver	4 x 100
Slotted Screwdriver	5.5 x 125
Phillips Screwdriver	PH1 x 80
Phillips Screwdriver	PH2 x 100



HTJT100 - Jet Torch

- Powerful butane gas lighter with an adjustable jet flame
- Adjustable flame
- Auto flame safety cut-off technology
- Child lock
- Used to easily heat Simple Solder connectors & terminals as well as heat shrink tubing.
- Dimensions (mm): 120(H) x 19(W)



TP100K - Soldering Kit (DIY)

- Adjustable gas flow
- Flint
- Self-ignitor
- Handy carry case
- Uses butane gas (SOLDEGAS)
- Refer to **TP100** for technical overview

Model Specification

Standard Accessories	Solder, Deflector, Hot knife, Chisel Tip, Angle Tip, Stand, Sponge, Handy Carry Case
-----------------------------	--

TP200 - Cordless Soldering Iron: 3 in 1



Soldering Iron



Heat Gun



Torch



- 3-Functions:
 - Soldering iron – Temperature: 200-400°C
 - Heat gun – Temperature: up to 400°C
 - Torch – Temperature: up to 1 300°C
- Soldering iron conical tip 1.6mm (W)

Technical Overview

Fuel	Butane (SOLDEGAS P150)
Operating time	60-60mins (80 w/fuel)
Gas container capacity (ml)	15
Dimensions (mm)	250(H0 x 30(T) x 25 (W)
Weight (g)	162 (no gas)

TP200K - Cordless Soldering Iron Kit: 3 in 1



Soldering Iron



Heat Gun



Torch



- 3-Functions:
 - Soldering iron – Temperature: 200-400°C
 - Heat blower – Temperature: up to 400°C
 - Torch – Temperature: up to 1 300°C
- Soldering iron conical tip 1.6mm (W)
- Soldering iron chisel tip 2.4mm (W)
- Refer to TP200 for Technical overview

Model Specification

Standard Accessories	TP200 Cordless Soldering Iron, Soldering iron conical tip 2.4mm, Soldering iron chisel tip 2.4mm, Hot knife, Deflector tip, Mini wrench, Sponge, Soldering wire (mm): 0.1, 15g
-----------------------------	--

SOLDEGAS - Clipper Butane Gas



- Butane
- Size: 250ml
- Ultra refined for maximum care and performance

Standard Nylon Cable Ties Selection Guide

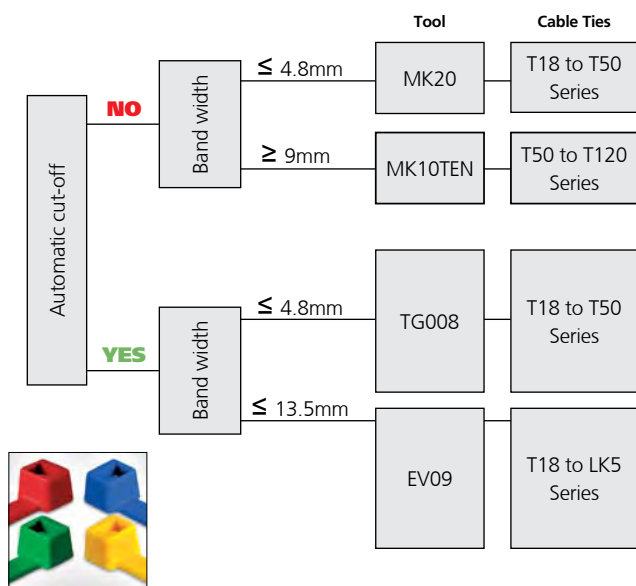

MK20 - Plastic Frame (Nylon)



- Nylon cable ties only
- Lightweight, ergonomic tool
- Suitable for **T18**, **T30** and **T50** series cable ties
- Mounted and pre-tensioned ties are cut off by twisting the tool
- Maximum width of tie: 4.8mm



Nylon cable tie tensioned and cut i.e. no sharp edges

TG008 - Steel Frame (Nylon)



- Adjusting tensioning force
- Lightweight tool ideal for continuous use in high volume production
- **T18**, **T30** and **T50** series cable ties
- Maximum width of tie: 4.8mm
- Dimensions (mm): 160(L) x 135(H) x 25(W)
- Weight: 300g



Nylon cable tie tensioned and cut i.e. no sharp edges

MK10TEN - Steel Frame (Nylon)

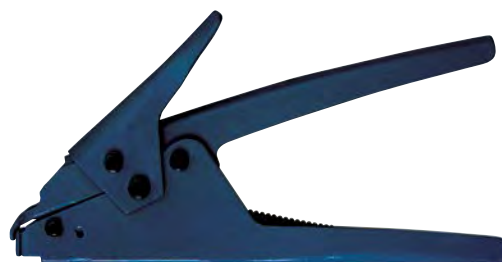

- Adjusting tensioning force
- Lightweight tool ideal for continuous use in high volume production
- **T18**, **T50** and **T120** series cable ties
- Maximum width of tie: 9.5mm
- Dimensions (mm): 190(L) x 95(H) x 30(W)
- Weight: 500g



Nylon cable tie tensioned and cut i.e. no sharp edges

EVO7i - Plastic Frame (Nylon)



- Adjustable preset tensioning tool
- Tensions and automatically cuts cable ties up to 4.8mm wide
- Extremely low maintenance
- Housing made of resilient and lightweight glass fibre-reinforced polyester MIL approved
- Dimensions: (mm): 191(L) x 33(W)
- Weight: 781g

RoHS ✓



Nylon cable tie tensioned and cut i.e. no sharp edges

EVO9 - Plastic Frame (Nylon)



- Ergonomic, slip proof handle for a comfortable and secure grip
- Quick tension adjustment with 3 integrated settings
- Fast and precise application with minimum effort
- Extremely low maintenance
- Maximum width 13mm
- Spare blade: **EVO9BLD**
- Dimensions (mm): 191(L) x 135(H) x 33(W)

RoHS ✓



Nylon cable tie tensioned and cut i.e. no sharp edges

EVOcut - Cutting Tool (Nylon)



- Cutting tool for nylon cable ties and fixing ties
- Prevents cable insulation from being damaged
- Cable tie can be cut off at any part of strap
- Single-handed operation
- Light-weighting plastic housing, ergonomic designed



Standard Metal Cable Ties Selection Guide

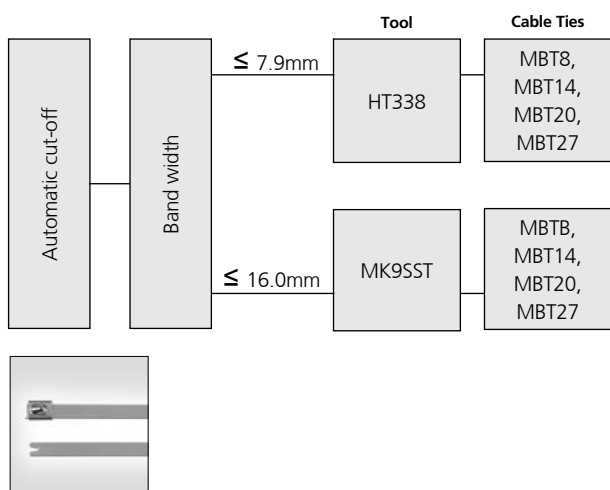

HT338 - Steel Frame (Stainless Steel)



- Fastens and automatically cut ties with adjustable bundling pressure
- Tension adjusting indicator
- Cable tie thickness up to 0.3mm, width up to 7.9mm
- **MBT8, MBT14, MBT20 and MBT27** cable ties



Stainless steel cable tie tensioned and cut i.e. no sharp edges

MK9SST - Plastic Frame (Stainless Steel)



- Lightweight tool ideal for continuous use in high volume production
- MBT series cable ties designed for SS316 only
- Maximum width of tie: 4.6 - 16mm
- Dimensions (mm): 190(L) x 150(H) x 40(W)
- Weight: 600g
- Spare blades: **HT338BLD, HT385RAT, SPMK9SST**



















Stainless steel cable tie tensioned and cut i.e. no sharp edges

Type		Description	Material	#Outdoor Application	Indoor Application	#UV Resistant	Weather Resistant	Flame Retardant
T Series		General purpose, inside serrated #Black only	PA66	*	*	*		
T Series Outdoor		UV & weather resistant, inside serrated	PA66W	*		*	*	
Q-Ties		Integrated pre-locking function, open head, inside serration	PA66		*	*		
OS Series		UV stabilised, outside serrated	PA66W	*		*		
OS Series		Heat stabilised, outside serrated	PA66HS		*		*	*
OS Series		Fire protection, outside serrated	PA66VD		*			
OS Series		Curved head, high temperature, outside serrated	PA46		*			
RPE Series (E.R. D.F. approved)		Low profile, releasable, reusable, outside serrated	PA66HSW		*	*		
PE Series		Low profile, outside serrated	PA66HSW*, PA66*		*	*		
LPH Series		Low profile, outside serrated	PA66, PA66W		*	*		
RT Series		Releasable, reusable, inside serrated	PA66		*	*		
RELK Series		Releasable, reusable, inside serrated	PA66		*	*		
RLT Series		Releasable, reusable, inside serrated	PA66*, PA66W*, PA66HS*	*	*	*	*	
REL Series		Releasable, reusable, inside serrated	PA66, PA66W	*		*		
SRT Series		Releasable, reusable, without serration	TPU		*			
PEEK Ties		High temperature, outside serrated	PEEK		*			*
SpeedyTie®		Quick release	PA66		*	*		
KR Series, 1 Piece		Glass Fibre Pin, without serration	PA66, PA66W, PA66HS	*		*		
KR Series, Endless		Glass Fibre Pin, without serration	PA66HS, PA66W		*			
MCT (FDA, HACCP approved)		Detectable, Metal Content, inside serrated	PA66MP					
MBT Range		Stainless steel, metal ball bearing	SS316	*		*	*	
MST		Punch-locking mechanism	SS304	*		*	*	
LFPC		Protective channel for stainless steel cable ties	PO	*	*	*	*	

**Colour Abbreviation Table*

BK	Black	BN	Brown	RD	Red	OG	Orange	YL	Yellow	GR	Green	BL	Blue	VT	Violet	PK	Pink	GY	Grey	WT	White	NT	Natural	BGE	Beige
----	-------	----	-------	----	-----	----	--------	----	--------	----	-------	----	------	----	--------	----	------	----	------	----	-------	----	---------	-----	-------

Heat Stabiliser	Length (mm)	Width (mm)		MAX Cable Bundle DIA (mm) Range	**Colour	Operating Temperature	Flammability	Material Specification	Industry
	100 to 535	2.5 to 13.2	80 to 1115	22 to 150	BK ■ BL ■ BN ■ GR ■ OG ■ PK ■ RD ■ VT ■ YL ■ WT ■	-40°C to +85°C	UL94 V2	HF ✓ RoHS ✓	Various
	83 to 535	2.3 to 13.2	80 to 1115	16 to 150	BK ■	-40°C to +85°C	UL94 V2	HF ✓ RoHS ✓	Various
*	105 to 520	2.6 to 7.7	80 to 530	24 to 145	BK ■ NT ■	-40°C to +85°C	UL94 V2	HF ✓ RoHS ✓	Various
*	150 & 200	4.6	225	35 & 50	BK ■	-40°C to +85°C	UL94 V2	HF ✓ RoHS ✓	
*	100 to 384	2.5 to 4.6	80 to 225	20 to 110	BK ■ NT ■	-40°C to +105°C	UL94 V3	HF ✓ RoHS ✓	
*	145	3.4	135	35	NT ■	-40°C to +85°C	UL94 V3	HF ✓ RoHS ✓ LFH ✓	
	150 to 245	4.6	35 to 66	225	GY ■ NT ■	-40°C to +150°C	UL94 V3	HF ✓ RoHS ✓	
*	180 to 400	9	330 to 445	42 to 146	BK ■	-40°C to +105°C	UL94 V2	HF ✓ RoHS ✓	Various
*	275 to 359	9	445	69 to 92	BK ■ BL ■ GN ■ RD ■ YL ■	-40°C to +105°C	UL94 V2	HF ✓ RoHS ✓	
	175 to 355	9	310 to 480	40 to 92	BK ■	-40°C to +85°C	UL94 V2	HF ✓ RoHS ✓	
	565.3 to 1030	12.7	1115	150 to 305	BK ■ NT ■	-40°C to +85°C	UL94 V2	HF ✓ RoHS ✓	
	200 to 350	4.6	200	50 to 95	BK ■ NT ■	-40°C to +85°C	UL94 V2	HF ✓ RoHS ✓	
*	340 to 770	7.6 to 8.9	535 to 670	90 to 225	BK ■ NT ■	-40°C to +85°C	UL94 V2	HF ✓ RoHS ✓	
	100 to 250	6.5 to 7.6	150 to 200	21 to 68	BK ■ NT ■	-40°C to +85°C	UL94 V2	HF ✓ RoHS ✓	
	180 to 580	7 to 28	57 to 360	45 to 150	BK ■	-40°C to +85°C	UL94 HB	HF ✓ RoHS ✓	
	145	3.4	230	35	BGE ■	-55°C to +240°C	UL94 VD	HF ✓ RoHS ✓ LFH ✓	
	750	13	888	210	YL ■	-40°C to +85°C	UL94 V2	HF ✓ RoHS ✓	Various
*	210 to 600	6.1 to 8	390 to 785	47 to 184	BK ■ NT ■	-40°C to +85°C	UL94 V4	HF ✓ RoHS ✓	
	5000	8	785	N/A	BK ■ NT ■	-40°C to +85°C	UL94 V5	HF ✓ RoHS ✓	
	390	2.5 to 7.6	85 to 380	22 to 110	BL ■	-40°C to +85°C	UL94 HB	HF ✓ RoHS ✓	
	127 to 838	4.6 to 12.3	670 to 2225	25 to 254		-80°C to +538°C	Non-burning	HF ✓ RoHS ✓ LFH ✓	Various
	207 to 700	5.9 to 8.9	900 to 1500	50 to 205		-80°C to +538°C	Non-burning	HF ✓ RoHS ✓ LFH ✓	Various
	25 to 50m	7 to 16.3	N/A	N/A	BK ■	-40°C to +90°C	UL94 V0	HF ✓ RoHS ✓ LFH ✓	Various

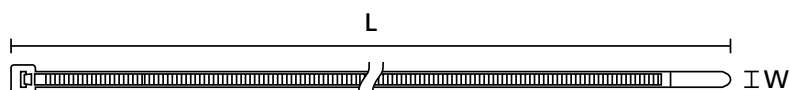



HG2120E - Steinel Heat Gun (Professional)

- Thermal cut-out
- Temperature indication by thumb wheel in 9 steps

Technical Overview

Output	2200W
Operation hours	750
Temperature (°C)	80 – 630°C
Airflow rate (3 steps)	150-500l/min
Heating element	Ceramic
Protection class (without earth terminal)	II
Weight (g)	670

Model Specification

Optional Accessories	NOZREF Reflector Nozzle, NOZSUR50 50mm Surface Nozzle, NOZRED9 9mm Reduction Nozzle, NOZRED14 Nozzle Reducer 14mm, NOZREF10 Nozzle Solder Reflector 10mm, NOZSUR75 Nozzle Shaping Surface 75mm, NOZWIDE14 Nozzle Welding Wide-Slit 14mm (P142)
----------------------	--



HL1920E – Steinel Heat Gun

- 9 Step thumb wheel temperature adjustment
- Thermal fuse

Technical Overview

Output	2000W
Operation hours	600
Temperature (°C)	80 – 600°C
Airflow rate (3 steps)	150-500l/min
Heating element	Ceramic
Protection class (without earth terminal)	II
Weight (g)	840

Model Specification

Optional Accessories	NOZREF Reflector Nozzle, NOZSUR50 50mm Surface Nozzle, NOZRED9 9mm Reduction Nozzle, NOZSUR75 Nozzle Shaping Surface 75mm (P142)
----------------------	--



HL1821S - DIY Steinel Heat Gun

- Thermal fuse
- Two step heating setting

Technical Overview

Output	1800W
Operation hours	600
Temperature (°C)	300 or 550
Airflow rate	350 or 450l/min
Heating element	Micanite
Protection class (without earth terminal)	II
Weight (g)	717

Model Specification

Optional Accessories	NOZREF Reflector Nozzle, NOZSUR50 50mm Surface Nozzle, NOZRED9 9mm Reduction Nozzle (P142)
----------------------	--



CHG900 - Gas Heat Gun - Heavy Duty

The HellermannTyton CHG900 Cordless Heat Gun is powered by P445 gas cartridges, providing autonomous working of 90 minutes in one go. The tool is designed to produce flameless heat which makes it the ideal hot-air gun to apply a huge variety of heat shrink tubing and heat shrink wire markers as well as molded shapes or heat shrink boots, transition shapes, end caps and cable repair sleeves especially in harsh outdoor conditions covering freezing temperatures as low as -8°. CHG900 replaces the obsolete E4500 hot-air tool which will be discontinued upon CHG900 launch.









Technical Overview

Operating temperature	+190 °C to +900 °C
Ambient operation temperature	-8°C to +50°C
Operating time	90 minutes per cartridge (60min continuously)
Power	520 W / 1700 BTU
Weight	440g (555g incl Cartridge)

Model Specification

Optional Accessories	P444 gas cartridge 1 x Reduction Nozzle 1 x Reflection Nozzle
----------------------	---



CODE	DESCRIPTION	HG2120E	HL1920E	HL1821S
PAGE		151	151	151
	NOZRED14 Nozzle Reducer 14mm Suggested Use: Concentrated air flow, adapter for wide slit nozzle		<input type="radio"/>	<input type="radio"/>
	NOZRED9 Nozzle Reducer 9mm Suggested Use Delivers hot air with pinpoint precision for de-soldering and welding plastics with welding nozzle	<input type="radio"/>	<input type="radio"/>	<input type="radio"/>
	NOZREF Nozzle Reflector Suggested Use Soldering pipes, fitting heatshrink tubing, thawing frozen pipes and bending pipes.	<input type="radio"/>	<input type="radio"/>	<input type="radio"/>
	NOZREF10 Nozzle Solder Reflector 10mm Suggested Use Soldering and heatshrink-fitting soldering sleeves and shrink-on tubing in cable harnesses		<input type="radio"/>	<input type="radio"/>
	NOZSUR50 Nozzle Surface 50mm Suggested Use Evenly drying, stripping paint and removing films	<input type="radio"/>	<input type="radio"/>	<input type="radio"/>
	NOZSUR75 Nozzle Shaping Surface 75mm Suggested Use Evenly drying repair filler, stripping paint and removing films		<input type="radio"/>	<input type="radio"/>
	NOZWIDE14 Nozzle Welding Wide-Slit 14mm Suggested Use Welding plastic sheeting and tarpaulins		<input type="radio"/>	<input type="radio"/>

Optional



GLUEPRO400 – Steinel Hot-Melt Glue Applicator (Professional)

- Display for monitoring temperature to the (accuracy of 1°)

Technical Overview

Warm-up time	< 2 min
Temperature (°C)	40 – 230°C (accuracy +2°C)
Delivery rate	1.5 kg/h
Output during heat-up phase	400W
Weight (g)	600

Model Specification

Optional Accessories	Glue sticks dia. 11mm Compatible STEINEL hot-melt adhesives				
	Glue Universal 190 °C	Glue Flex 190 °C	Glue Fast 190 °C	Glue Low 130 °C	Glue Acrylate 130 °C



Glue Stick Selection Guide

Code	GLUEUNIVERSAL	GLUEACRYLATE	GLUEFAST	GLUEFLEX	GLUELOW
Uses	Multi-purpose	High resistance, temperature stable	Multi-purpose	Transparent	Low temperature
Temperature (°C)	190	200	190	190	130
Strong bond: approx.	60-90s	60s	30s	100-120s	40s
Firm after	15s	15s	8s	60-80s	80s
Material					
Wood	•	•	•	•	
Card/cardboard boxes	•	•	•	•	•
Rubber		•	•		•
Glass	•		•		
Ceramic	•		•		
Metal	•	•			
Melamine	•	•			
PA	•			•	
PC	•	•	•	•	
PE	•		•	•	
PET	•	•		•	
Plexiglas®		•	•	•	
POM	•				•
PP	•		•	•	
PS		•			
PVC	•	•	•	•	
Rigid PVC	•			•	•
PU foam					•
Polystyrene					•

Times and recommended adhesive are a rough guide only

Other options available:

GLUEULTRA 7m,11m

GLUECRYSTAL240 7mm

HEADLIGHT - LED



- 1PCS COB LED (White and Red)
- Function - white LED
- Low - White LED
- High - red light
- On - red light SOS
- Press button "A" to get the sensor function
- Waterproof grade: IP54
- Size: 38 x 45 x 66.5 mm
- Weight: 44g (excluded battery)

IP54

Maximum Output	210LM(High),110LM (Low)
Power Source	3 x AAA Batteries
Runtime	3 hours (High), 7 hours (Low)
Beam Distance	24 meters (COB white)

LEDTORCH - LED



- Weatherproof
- Anti-drop 1.2m
- Taicap switch
- Length: 145mm

Maximum Output	40Lm
Power Source	2 x AA Batteries
Runtime	3hrs on high, 40Lm
IP Rating	X4